

Strange

**PRO SERIES 4-PISTON
REAR BRAKE KIT
INSTRUCTIONS**

KIT #
B1714WC, B1714WCM

APPLICATIONS
C-clip elim for Ford Mustang / 8.8
rear ends using Strange Axles.

Before you begin installation:

- Strange Engineering brake kits are designed for DRAG RACING ONLY!
- Read these instructions thoroughly and save for future reference.
- Brake fittings do not come pre-installed, it will need a layer of Teflon sealer applied to the thread (Figure#1 for torque specs)
- If after reading these installation instructions, you have any questions or comments, please do not hesitate to call us.

KIT CONTENTS

ITEM#	PART#	QTY	DESCRIPTION
1*	A1090A	2	Strange inner hub for 8.8 rear end
2*	A1090B	2	Strange outer hub for 8.8 rear end
3*	A1011	2	Timken 1.563" x 2.875" axle bearing (installed in A1090A)
4*	A1090C	2	Wedding ring
5	A1092E	4	Hub gasket
6*	A1090F	2	Bearing seal (installed in A1090B)
7*	A1092C	8	3/8-24 x 2.344" long stud (installed in A1090B)
8	B1714A	1	L.H. Mustang/8.8 rear caliper bracket
9	B1714B	1	R.H. Mustang/8.8 rear caliper bracket
10	B1301E	4	3/8-24 Press nut (installed in B1714A & B1714B)
11	B5002	1	R.H. 4-piston caliper
12	B5004	1	L.H. 4-piston caliper
13**	B5010	4	Soft 4-piston caliper pads
14**	B5020	4	Hard metallic 4-piston caliper pads
15	B5000Y	4	3/8-24 Caliper bolt
16	B1301J	4	3/8" Washer
17	B1301H	16	Stainless caliper shim
18	P2316	2	1/8" NPT x -3AN Fitting
19	B2792	1	R.H. HD/MD directional rotor
20	B2793	1	L.H. HD/MD directional rotor
21*	F1282	8	3/8-24 "Jet" nut
22*	S3402N	8	3/8 AN washer

* C-Clip eliminator kit must be purchased separately ** Actual contents will vary depending on application and will be determined when ordering

FIGURE # 1: Exploded B1714WC Assembly View

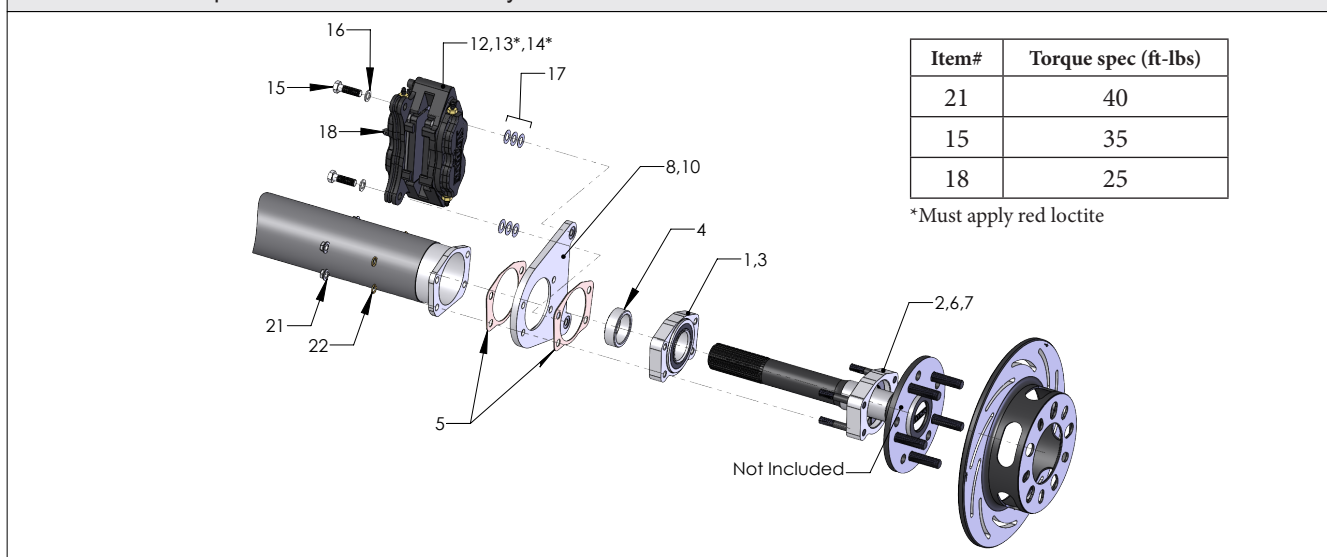

Installation instructions

1. Raise and support rear of vehicle on a level surface using suitable equipment.
2. Place drain pan under rear-end cover and begin slowly removing the bolts and prying the cover, starting at the bottom to allow the gear oil to drain.
3. Remove wheel, stock drums, backing plate, differential cover, cross pin bolt, and cross pin. Push axle flange inboard to remove c-clip and slowly slide out the axles.
Note: This kit replaces stock brake components, axle bearing, and c-clips with c-clip eliminator.
4. Remove stock axle bearing, and seal using a slide hammer.
5. Using a hacksaw, remove stock snouts (see figure 2): leaving only the backing plate register and file ALL sharp edges and burrs.
6. Install inner hub (1*,3*), and outer hub (2*,6*,7*) assembly onto the axle, pressing only on the inner race of the axle bearing (3*) making sure the 3/8-24 studs (7*) point away from the axle flange. Before installing, apply a small amount of oil to the I.D. of the bearing to aid in installation. Make certain that the bearing is fully seated against the step on the axle.
Note: The I.D. of the axle bearing used is bigger than the stock axle diameter; therefore this kit MUST be used with Strange racing axles. Contact Strange Engineering for application and ordering information.
Note: The gap present between the two aluminum halves is the result of a preload placed on the Timken bearing (3); Therefore, RTV gasket sealer must be applied to seal the gap (Refer to figure 3).
7. Slip the wedding ring (4*) over the axle. Using a hydraulic press, to press the wedding ring (4) EVENLY until it seats flush against the bearing (3*).
8. Apply RTV Gasket Sealer to both sides of the provided paper gaskets (5). Slide caliper bracket (8,9) over the 3/8-24 long studs (7*) with one gasket between the bracket (8,9) and the Strange hub assembly (1*,2*). Ensure that the press nuts (10), installed in the caliper bracket (8,9) face OUTBOARD.
Note: Caliper brackets (8,9) can be mounted on either side of the vehicle depending on desired caliper location. e.g. mounting the R.H. caliper bracket (9) on the driver's side will relocate the caliper from the 3:00 to the 9:00 position. (Refer Figure 4)
9. Place one gasket (5) between the caliper bracket (8,9) and housing end flange. Install axle, caliper bracket (8,9), and Strange hub assembly (1,2), engaging the 3/8-24 studs (7*) through the stock housing end, using the 3/8" AN washer (22*), and 3/8-24 "jet" nut (21*). Torque to 40 ft-lbs.
10. Slide the rotor (19,20) over the wheel studs and axle flange, ensuring that the rotor sits flat on the face of the axle flange.
Note: Slotted rotors mount with the arrow pointing in the direction of normal rotation (Refer to Figure 4).
 - Please read B1850 instructions for complete caliper instructions if using soft pads.
 - Please read B1855 instructions for complete caliper instructions if using hard metallic pads.
11. Attach caliper (11,12) with the arrow facing in the direction of normal rotor rotation using 3/8"-24 caliper bolts (15) with red loctite and 1/16" thick flat washers (16). Use 0.025" thick caliper shims (17) to center the caliper over the rotor, making sure pads contact the rotor evenly. The caliper bolt (15) should be fully engaged into the press nut. If the bolt is over engaged, use any remaining shims under the head of the bolt to prevent it from running into the rotor. Torque the caliper mounting bolts (15) to 35 ft-lbs.
12. Connect the brake lines to the calipers. Calipers are tapped to 1/8"-27 NPT and supplied with -3AN fittings. Use proper adapters to connect them to existing lines or use new -3AN braided steel line (teflon lined). Bleed the calipers with DOT 4 or DOT 5.1 brake fluid ONLY.
13. A proper break in procedure is required to avoid brake fade and uneven rotor deposits from the pads. It consists of 8-10 brake applications increasing in harshness while allowing the brakes to cool slightly in between; do not keep the brakes applied between stops. After the last stop the brakes should be allowed to cool completely.

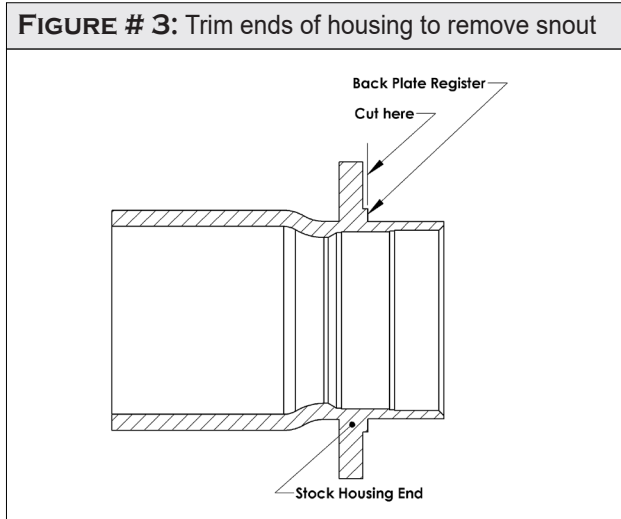

WARNING - RACING IS HAZARDOUS · STRANGE BRAKES ARE FOR LEGAL DRAG RACING ONLY

Disclaimer of Warranty - Purchasers using Strange Engineering racing components and equipment any and all inventory services, purchasers acknowledge that due to differing conditions and circumstances under which all equipment and parts are installed and used, purchasers are not relying on Strange Engineering Co. skill or judgment to select or furnish the proper part or equipment. Purchasers expressly affirm they are relying upon their own skill or judgment to select and purchase suitable goods. Strange Engineering Co. makes no warranties whatsoever, expressed or implied, oral or written, to purchasers. There is no warranty of merchantability made to purchasers. Strange Engineering Co., further excludes any implied warranty of fitness with respect to racing and equipment, any and all inventory and service.

FIGURE # 3: C-clip Emlinator Orientation

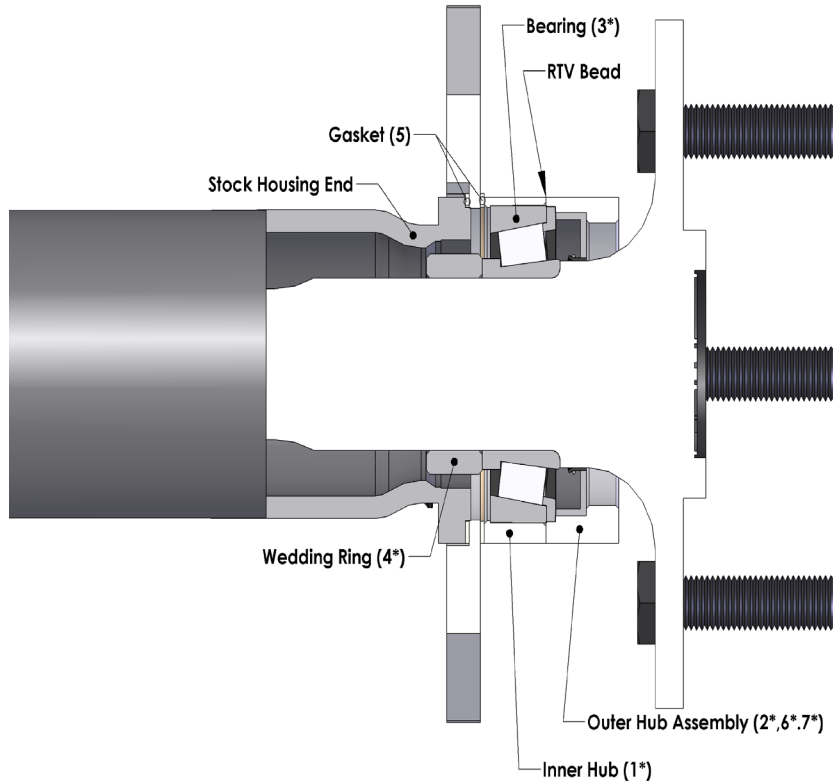

- Press on inner race of the Timken axle bearing (3*) so that it stops square against the shoulder of the axle.
- The two aluminum halves (1*, 2*) will have a slight gap between them in order to pre-load the Timken axle bearing (3*). It is necessary to apply a bead of RTV sealer between the two halves to seal the gap.
- THE WEDDING RING MUST BE PRESSED EVENLY AND SET FLUSH & SQUARELY AGAINST THE INNER RACE OF THE BEARING.

FIGURE # 3: C-clip Eliminator Orientation

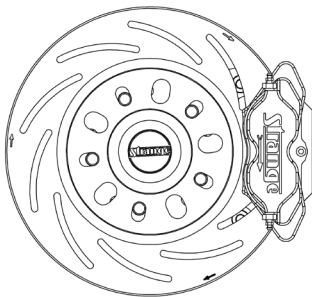

- Reverse orientation using R.H. caliper bracket (9)

9:00

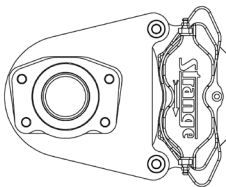

- Caliper orientation using L.H. caliper bracket (8)

3:00

