

STRANGE PRO RACE 11" REAR CARBON BRAKE KIT INSTRUCTIONS

KIT

C18104UC
C18105UC

APPLICATIONS

Symmetrical Housing ends
4-3/4" Bolt Circle
5" Bolt Circle

Important Notes

- Strange Engineering brake kits are designed for DRAG RACING ONLY!
- Carbon brake pads (L4050H1 & L4050H2) minimal thickness is 0.200".
- 11" Carbon rotors (C1790) minimal thickness is 0.300".

Before you begin installation:

Read these instructions thoroughly and save for future reference.

If after reading these installation instructions, you have any questions or comments, please do not hesitate to call us.

KIT CONTENTS			
ITEM #	PART #	QTY	DESCRIPTION
1	S3440D	8	3/8-24 x 1" HHCS GR8 housing end bolt
2	S3402N	8	3/8" AN Washer
3	C1710A	2	Carbon Ultra Caliper mounting bracket
4	B1301E	4	3/8"-24 Press Nut
5	S3402L	4	Forged S/A Bushing (Installed in B5006 & B5008)
6a	C1700M*	2*	Carbon rotor adapter for use with 4 3/4" b.c. (C18104UC)
6b	C1700K*	2*	Carbon rotor adapter for use with 5" b.c. (C18105UC)
7	C1700D	20	1/4"-20 x 1/2" FHSCS
8	C1700H	2	11" Carbon rotor retainer ring
9	C1790	2	11" Carbon rotor
10	B5000Z	4	3/8"-24 x 1.187" Caliper mounting bolt
11	B5046	1	Ultra Carbon Caliper kit
12	L4050H1	2	Slotted (directional) 4-piston carbon pad
13	L4050H2	2	Slotted (directional) 4-piston carbon pad
14	P2316	2	1/8" NPT x #3 AN Fitting

*Kit contents will depend on application based on bolt circle diameter. (does not affect assembly)

FIGURE # 1: Driver Side exploded view

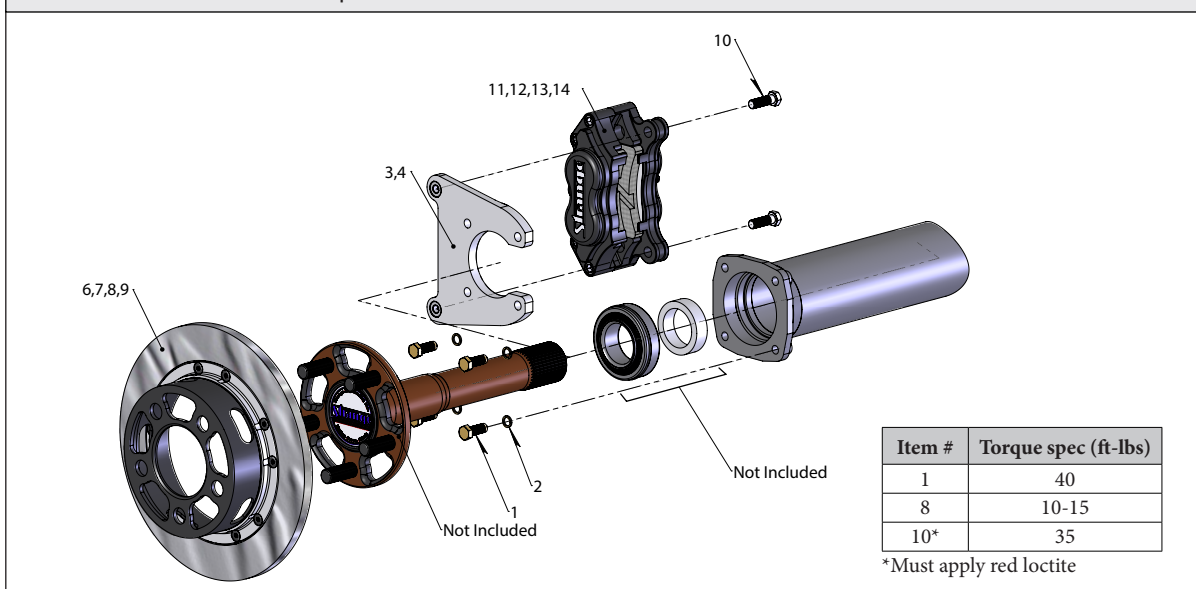

INSTALLATION INSTRUCTIONS

1. Raise and support rear of vehicle on a level surface using suitable equipment.
2. Remove wheel, axle, and existing brake setup.

Note: The slot in the caliper bracket (3) may enable you to install this kit without pulling the bearing and wedding ring from the axle. If you can remove your current brake setup without having to pull the bearings, inspect the bearings for signs of wear. If the bearings do not need to be replaced, then skip steps 3, 7 & 8.

3. Remove bearing, wedding ring, and brake bracket/retaining plate.
4. Check the axle for any signs of twisting or run out and repair or replace as needed. The maximum allowable run out checked between centers at the face of the flange, bearing surface, and near the splines is 0.005" total indicated run out (T.I.R.).
5. Inspect the rotor assembly for fit on the axle flange. The rotor adapter (6) should slide freely over the axle flange and seat flush against the face of the axle flange. The rotor adapter (6) must center on the axle flange or axle studs. If the axle flange is too large, it must be machined to 6.240" diameter.
6. Visually inspect the housing end for straightness and repair as needed.
7. Install a new bearing (not included) on the axle, pressing only on the inner race, making sure the seal faces the axle flange. Before installing apply a small amount of oil to the I.D. of the bearing to aid in installation. Make certain that the bearing fully seats against the step on the axle.
8. Press the wedding ring (not included) onto the axle until it seats flush against the bearing.
9. Slide the axle into the housing until the bearing bottoms out in the housing end.
10. Insert the ultra caliper mounting bracket (3) over the axle with the press nuts (4) facing OUTBOARD. Install caliper bracket (3) using the 3/8" AN washers (2) and 3/8-24 housing end bolts (1). Torque to 40 ft-lbs.
Note: Ultra caliper mounting bracket (3) can be positioned so that the caliper is facing either up, down or towards the front or rear of the vehicle depending on application and/or desired orientation.
11. Slide the rotor assembly over the wheel studs and axle flange. Rotors come preassembled from Strange Engineering. However, if you ever need to disassemble the rotor, reassemble it by placing the rotor (9) between the retaining ring (8), and the adapter (6). Secure using 1/4-20 x 1/2" flat head socket bolts (7) and torque to 15-20 ft-lbs. Re-torque before every event to 15-20 ft-lbs.
Note: During re-assembly of rotor ensure that the large counterbore on the 11" carbon rotor (9) faces OUTBOARD; otherwise the retainer ring (8) will not fully seat on the rotor (9) and FAILURE will occur. (Refer to figure 2)
-Please read B5046 instructions for complete carbon ultra caliper instructions.
12. Attach caliper (11) using the 3/8"-24 caliper bolts (10). Torque the caliper mounting bolts (10) to 35 ft-lbs.
13. Connect the brake lines to the calipers. Calipers are tapped to 1/8"-27 NPT and supplied with -3AN fittings. Use proper adapters to connect them to existing lines or use new -3AN braided steel line (teflon lined). Bleed the calipers with DOT 4 or DOT 5.1 brake fluid ONLY.

Note: After the initial installation of this kit, ensure that there is adequate clearance between all braking and chassis components by moving the suspension all the way up and down throughout its travel. Additionally, make sure that the brake lines are not subject to binding or kinking. Operate the vehicle in a cautious manner until you determine that the brakes are functioning properly. Check and re-torque all bolts before every event.

Note: Rear Carbon Brakes perform best with caliper pressure from 1,100-1,200 psi

Note: Pads should be replaced when thickness equals .200" or less. Replace rotors when thickness equals .300" or less. Rotors wear concave and pads wear convex; therefore, measure rotor thickness in the middle of the rotor and pad thickness in the area where there are no pistons.

Note: Keep Carbon away from all chemicals. If contamination occurs the carbon component must be baked for 8 hours @ 500° F-(Bake Carbon ONLY! REMOVE ALUMINUM HAT & HARDWARE BEFORE BAKING)- If badly contaminated an odor will occur.

Note: The HOTTER the rotors become, the MORE EFFECTIVE braking becomes. Carbon brakes will stop your vehicle far better at the "top end" and will not "hold" as well at the starting line, compared to steel brakes. We recommend that when you first drive or "tow" your vehicle to the starting line, you apply the brakes several times to get the "feel" of carbon at low speeds. After you become comfortable with the vehicle at "pit area" speeds, you may want to "drag" the brakes to create rotor and pad heat to better hold the vehicle at the starting line. We recommend a few 1/2 or 3/4 passes, so as to become aware of how your carbon brakes perform at higher M.P.H. Remember carbon works better at higher temperature. The longer the brakes are applied the more aggressive braking will become.

FIGURE # 2: Carbon Rotor Exploded View

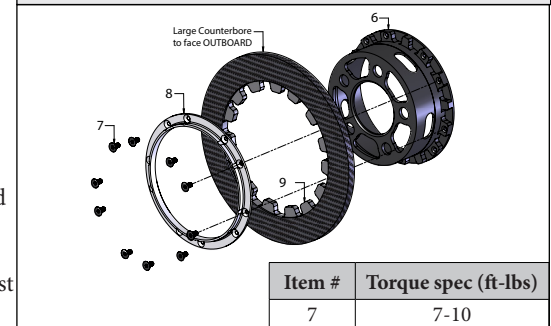

WARNING – RACING IS HAZARDOUS

Disclaimer of Warranty – Purchasers using Strange Engineering racing components and equipment any and all inventory services, purchasers acknowledge that due to differing conditions and circumstances under which all equipment and parts are installed and used, purchasers are not relying on Strange Engineering Co. skill or judgment to select or furnish the proper part or equipment. Purchasers expressly affirm they are relying upon their own skill or judgment to select and purchase suitable goods. Strange Engineering Co. makes no warranties whatsoever, expressed or implied, oral or written, to purchasers. There is no warranty of merchantability made to purchasers. Strange Engineering Co., further excludes any implied warranty of fitness with respect to racing and equipment, any and all inventory and service.