

# Strange

**GT BRAKE ADAPTER  
KIT INSTRUCTIONS**

**KIT #**  
B1706MC, B1706MCC

**APPLICATIONS**  
Late Big housing ends 94-04 OEM  
Mustang GT or Cobra disc brakes

**Before you begin installation:**

- Read these instructions thoroughly and save for future reference.
- 1994-2004 Mustang brake offset (F) is 3.250". Typical brake offset (F) for Late Big Ford ends is 2.500. Brackets move the calipers inboard 0.750" to make up the difference.
- If after reading these installation instructions, you have any questions or comments, please do not hesitate to call us.

KIT CONTENTS			
ITEM#	PART#	QTY	DESCRIPTION
1	B1300HS	8	3/8"-24 x 1" Housing End Stud
2	F1282	8	3/8"-24 "Jet" Nut
3	B1706BL	1	L.H. Late Big Ford Caliper Mount (for 94-04 Mustang Brakes)
Not shown	B1706BLC	1	L.H. Late Big Ford Caliper Mount (for 94-04 Mustang Cobra Brakes)
Not shown	B1706BR	1	R.H. Late Big Ford Caliper Mount (for 94-04 Mustang Brakes)
Not shown	B1706BRC	1	R.H. Late Big Ford Caliper Mount (for 94-04 Mustang Cobra Brakes)
4	A1026B	4	Caliper bolt washer
R1	A1094EM*	Optional	94-04 Mustang Reluctor Ring
R2	A3000B	-	7/8" Wide bearing spacer
R3	A1013C	-	SKF 18881 Seal
R4	A1013A	-	Timkin bearing
R5	A1090C	-	3/8" Wide wedding ring

**FIGURE # 1: Driver's side shown with GT brakes (B1706MC) and optional reluctor ring**

Item#	Torque spec (ft-lbs)
2	35
Abs sensor bolt	35
Caliper bolt*	45

\*Must apply red loctite

Note: Parts listed R1-R5 are shown as a reference and are not included in the brake kit

### Installation instructions

1. If using ABS, press the reluctor ring (R1) onto the axle flush against the small step on the axle (See Figure #2). The raised nose of the reluctor ring must face the axle flange.

**Note:** The access hole in both the reluctor ring (R1) and axle must line up to allow for installation of the jet nuts (2). Refer to Figure #1.

**Note:** Axle studs must be installed in the axle before the reluctor ring is pressed on.

2. Press the 7/8" wide bearing spacer (R2) on the axle with the large chamfer facing the axle flange. Refer to Figure #2.
3. Slide the caliper mount (3) over the axle ensuring that the STRANGE logo faces inboard.
4. Assemble axle bearing (R4) and oil seal (R3) ensuring that the oil seal (R3) seats flush against the step on the axle bearing (R4).
5. Now press the axle bearing (R4) onto the axle making sure to press only on the inner race of the bearing (R4). To aid in installation, slightly oil the ID of the bearing (R4). Make sure the shoulder of the bearing (R4) is fully seated against the bearing spacer (R2).
6. Press the wedding ring (R5) onto the axle until it seats flush against the bearing (R4).
7. Install the housing studs (1) from the backside of the housing end flange and hammer them into place until they are flush with the back of the housing end.
8. Slide the axle assembly into the housing end until the bearing (R4) bottoms out in the housing end.
9. Turn the axle to line up the access holes with the housing end studs (1) and install a jet nut (2) by inserting the jet nut (2) into a socket and feeding it through the access holes. Torque to 35 ft-lbs.

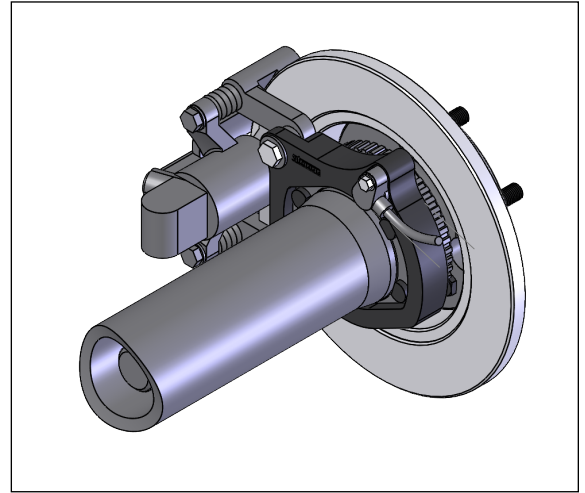

**FIGURE # 1: Bearing Assembly (w/ optional abs)**

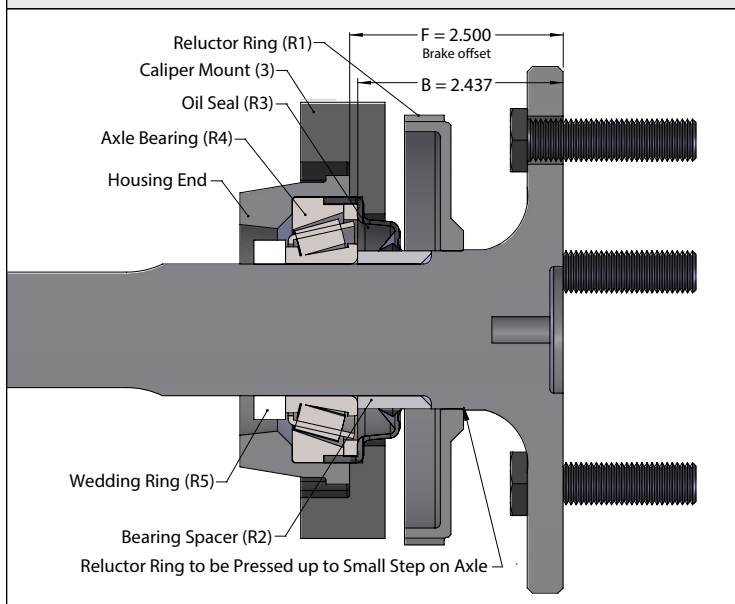

**Note:** The caliper mount must be oriented with the abs sensor facing the front of the car.

10. If using ABS, install the factory sensor in the caliper mount (3) using the stock 6mm bolt. Torque to 5 ft-lbs.
11. Slide the factory rotor over the wheel studs making sure the rotor will seat flush against the face of the flange.
12. Install the factory brake caliper using the factory 12mm bolts with red loctite and caliper bolt washers (4). Torque to 45 ft-lbs.
13. Mount wheel and tire and torque lug nuts to the recommended specification of the wheel manufacturer.

**Note:** After the initial installation of this kit, ensure that there is adequate clearance between all braking and chassis components by moving the suspension all the way up and down throughout its travel. Additionally, make sure that the brake lines are not interfering with the wheel travel, or subject to binding or kinking. Operate the vehicle in a cautious manner until you determine that the brakes are functioning properly. Routinely check and re-torque all bolts.

#### WARNING - RACING IS HAZARDOUS - STRANGE BRAKES ARE FOR LEGAL DRAG RACING ONLY

Disclaimer of Warranty - Purchasers using Strange Engineering racing components and equipment any and all inventory services, purchasers acknowledge that due to differing conditions and circumstances under which all equipment and parts are installed and used, purchasers are not relying on Strange Engineering Co. skill or judgment to select or furnish the proper part or equipment. Purchasers expressly affirm they are relying upon their own skill or judgment to select and purchase suitable goods. Strange Engineering Co. makes no warranties whatsoever, expressed or implied, oral or written, to purchasers. There is no warranty of merchantability made to purchasers. Strange Engineering Co., further excludes any implied warranty of fitness with respect to racing and equipment, any and all inventory and service.