

Installation instructions for Strange Steering Box

Features of the Strange Steering Box:

- Black anodized aluminum body
- Pocket milled pitman arm
- CNC Profiled, nitrided, and REM polished worm gear for maximum wear resistance and minimal “play”
- 3 Different sector shaft lengths for alcohol, fuel and nostalgia funny cars
- Set screw to adjust sector shaft end play
- Mounting holes on both sides of the steering box for rigid mounting
- 3/4” Dia. stainless steel sector shaft
- 10:1 Steering ratio (number of turns of input shaft / number of turns of output shaft)
- Total weight of 5.25 lbs.
- Two full turns of steering wheel lock to lock
- 5/8-36 serration input shaft

KIT CONTENTS

Item#	Part#	Qty.	Description
1	S3441E	1	Steering Box Splined Input Sleeve
2	S3441U	3	1/4-20 x 7/8” 12 Point Screw
3	B1260E	3	1/4” Stripper Washer
4	S3441C	1	Steering Box Cover (3 holes)
5	S3441O	1	Steering Box Cover O-Ring #114
6	S3441K	2	Timken Bearing Cup (L21511)
7	S3441J	2	Timken Bearing (L21549)
8	S3441V	1	5/8” x 0.005” Shim
9	S3441D	1	Input Shaft/ Worm Gear
10	S3441A	1	Steering Box Housing
11	S3441R	1	5/16-18 Jam Nut
12	S3441Q	1	5/16-18 x .75” Dog Point Set Screw
13	S3441T	4	5/16-18 x 1” 12 Point Screw
14	B1260M	4	5/16” Stripper Washer
15	S3441B	1	Steering Box Cover (4 holes)
16	L4500J	1	Steering Box Cover O-Ring #037
17	H1135C	2	1/2-20 Flexlock Nut
18	S3441G	1	Steering Box Swing Arm
19	S3441H	1	Steering Box Swing Pin
20	S3441N	1	3/4” x .031” Shim
21	S3441P	1	O-Ring #210
22	S3441F (S/M/L)	1	Sector Shaft
23	S3441I	1	Pitman Arm

Important notes:

- Shim (8) is used to fine tune input shaft/ worm gear preload.
- Steering box splined input sleeve (1) may need to be welded to a steering wheel assembly. For welding reference splined input sleeve is made from AISI 1026 steel. Engage splined input sleeve and assembly with input shaft/ worm gear (9). Then drill hole through input splined sleeve and input shaft/ worm gear to secure with a pin.
- NLG12 or equivalent grease is packed in the steering box.

Before you begin installation:

Read these instructions thoroughly and save for future reference.

If after reading these installation instructions, you have any questions or comments, please do not hesitate to call us.

Installation instructions for Strange Steering Box

Figure #1: Strange Steering Box Dimensions & Applications

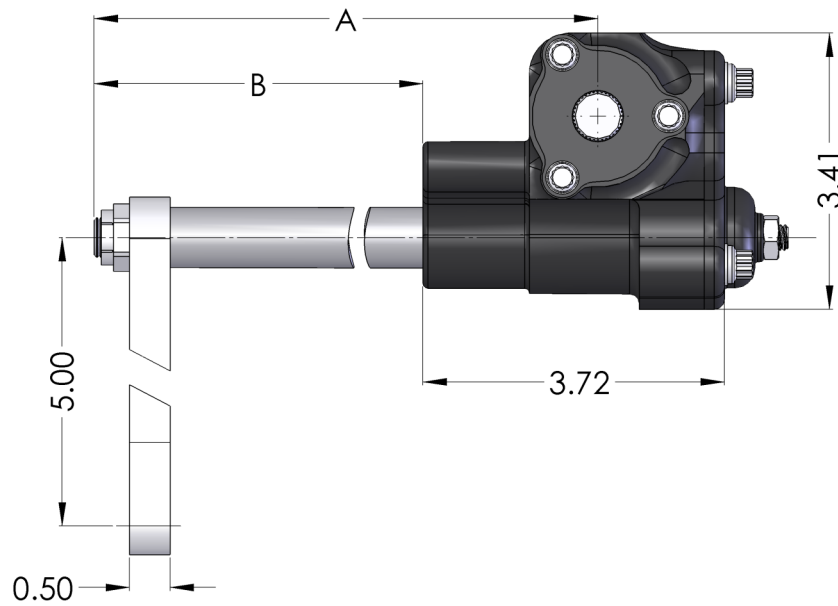

Strange Steering Box Dimensions and Applications

Part#	A	B	Sector Shaft Length	Application
S3441S	13"	10.875"	14.625"	Alcohol FC
S3441M	14"	11.875"	15.625"	Fuel FC
S3441L	15"	12.875"	16.625"	Nostalgia FC

Figure #2: Strange Dragster Box Exploded View

(item #'s correspond to kit contents table)

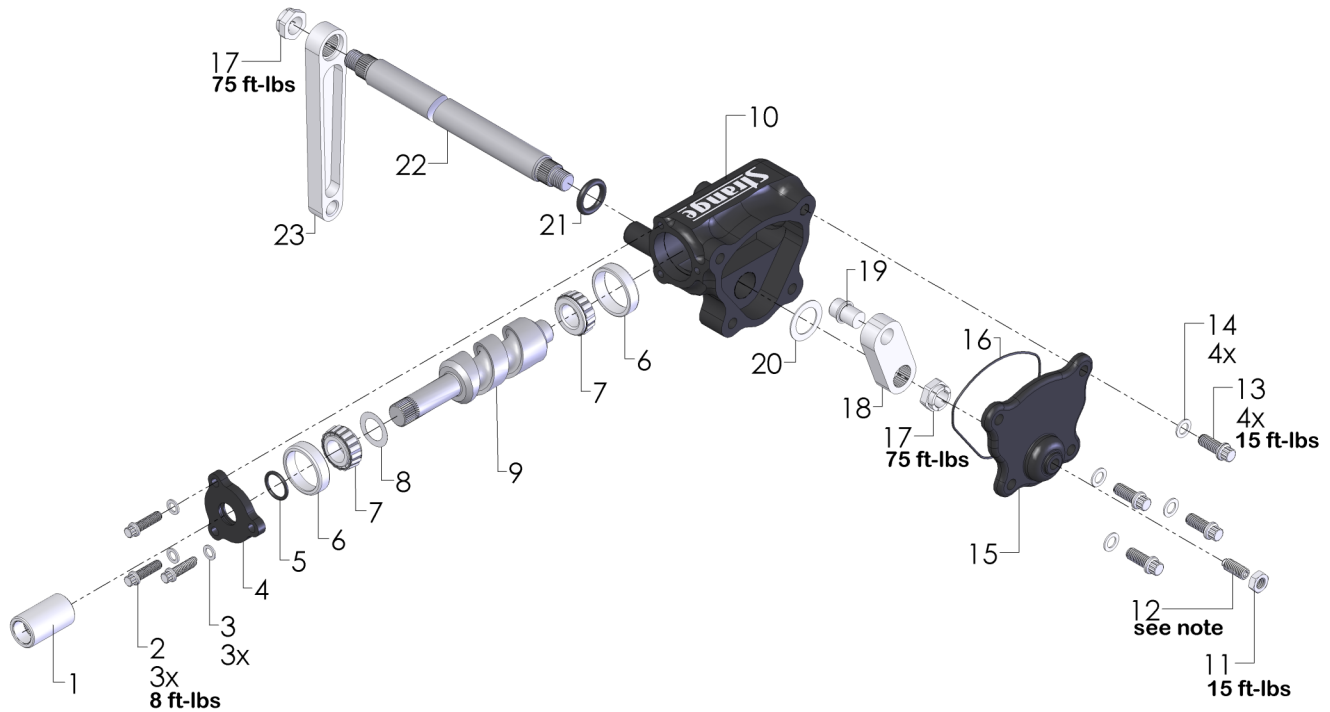

Note: Install set screw (12) until it contacts the sector shaft (22) to minimize shaft end play. Then torque jam nut (11).

Installation instructions for Strange Steering Box

Figure #3: Strange Steering Box Mounting Reference

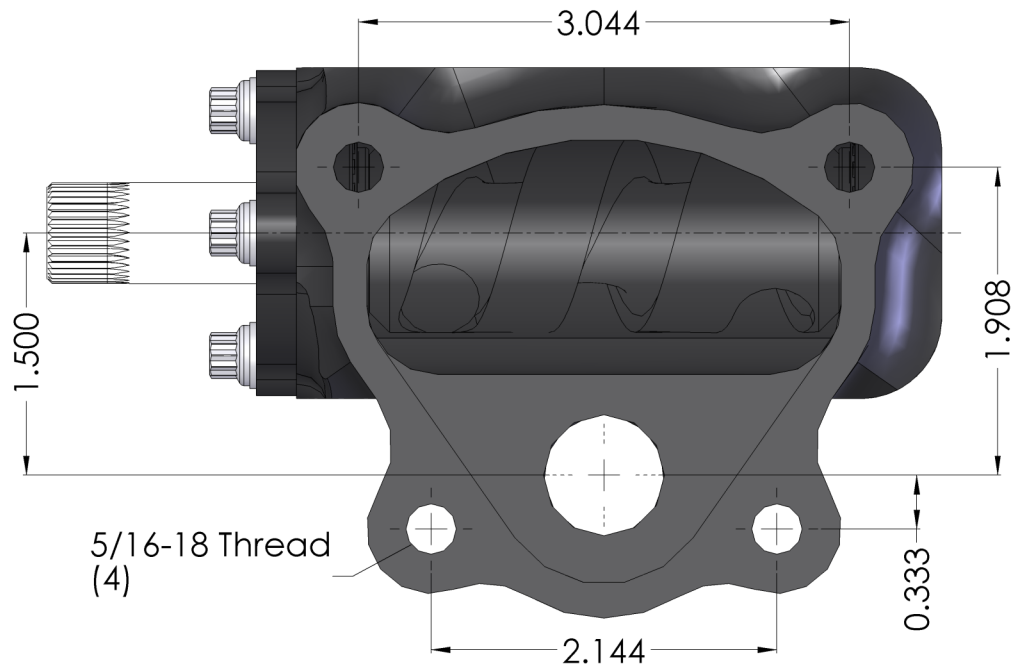

Figure #4: Strange Steering Box Mounting Reference

