

## DUAL OUTLET INLINE MASTER CYLINDERS

**KIT #**  
B3359, B3360

## APPLICATIONS

Vehicles with front and rear manual disc brakes

KIT CONTENTS FOR B3359 & B3360		
ITEM#	QTY	DESCRIPTION
B3360E	3	5/16"-18 locknut
B3360G	2	5/16"-18 x 1-3/4 bolt
B3360B	1	5/16"-18 x 1-1/4 bolt
B3360D	2	Reinforcing plate
B3359T/B3360T	1	Master Cylinder
B3359C	2	1/2"-20 adapter
B3359E	2	3/16" Hard line flare nut
B3359H	1	Dust Boot

KIT CONTENTS FOR B3359TA & B3360TA		
ITEM#	QTY	DESCRIPTION
B3359T/B3360T	1	Master Cylinder
B3359C	2	1/2"-20 adapter fitting
B3359E	2	3/16" Hard line flare nut
B3360H	1	Dust Boot

### Mounting Dimensions

Note: Shown with B3360D reinforcing plates ■

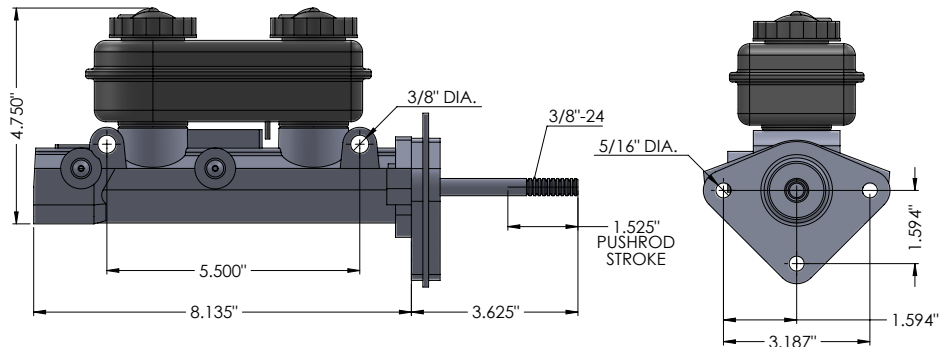

### Plumbing:

- B3359T master cylinder has a 1.125" diameter bore (Optimum for vehicles with four piston calipers front and rear)
- B3360T master cylinder has a 1.032" diameter bore (Optimum for vehicles with four piston calipers on the rear and two piston or single piston calipers on the front)
- Both outlet ports are tapped to 1/2"-20 inverted flare
- The supplied adapters (B3359C) will adapt the outlet ports to take a 3/16" diameter hard line
- Both outlet ports will supply the same pressure
- The outlet port nearest the pushrod supplies the most fluid volume and should be plumbed to the calipers requiring the most volume. Typically a drag race only car will have the largest calipers on the rear, while a street driven car will have the largest calipers on the front. Attach lines accordingly.
- When using drum brakes an external 10 lb. residual valve must be installed as close to the master cylinder as possible only on the port that connects to the drum brakes.
- If using -3 AN brakes lines, use adapter part# P2356 to connect them to the master cylinder ports.

**Installation:** Note: Installation must be performed by a professional mechanic

- Before installation it is **IMPERATIVE** that the master cylinder be bench bled. The majority of soft pedals result from not bleeding the master cylinder before it is installed.
  - To properly bench bleed remove the two plastic reservoir caps and run lines from the outlet ports into the reservoir.
  - Fill the reservoir with DOT 3, DOT 4, or DOT 5.1 brake fluid until the ends of the lines are covered.
  - Slowly cycle the pushrod in and out until there are no air bubbles coming from the lines
- Recommended pedal ratio for 1.032" diameter bore is 5.5 : 1.
- Recommended pedal ratio for 1.125" diameter bore is 6.5 : 1.
- Mounting bolt torque is 15-18 ft-lbs.
- After the master cylinder is installed, the brake system must be bled. Use only DOT 3, DOT 4, or DOT 5.1 brake fluid.
  - During the bleeding process the reservoir caps **MUST** be left loose or completely off to let air into the reservoir as the fluid level goes down. If the caps are left off, place a rag over the reservoir as fluid will shoot up from the tank.

WARNING - RACING IS HAZARDOUS - STRANGE BRAKES ARE FOR LEGAL DRAG RACING ONLY

Disclaimer of Warranty - Purchasers using Strange Engineering racing components and equipment any and all inventory services, purchasers acknowledge that due to differing conditions and circumstances under which all equipment and parts are installed and used, purchasers are not relying on Strange Engineering Co. skill or judgment to select or furnish the proper part or equipment. Purchasers expressly affirm they are relying upon their own skill or judgment to select and purchase suitable goods. Strange Engineering Co. makes no warranties whatsoever, expressed or implied, oral or written, to purchasers. There is no warranty of merchantability made to purchasers. Strange Engineering Co., further excludes any implied warranty of fitness with respect to racing and equipment, any and all inventory and service.