

# Strange

Page 1 of 3

May 25, 2022

## HEAVY DUTY FRONT BRAKE KIT INSTALLATION INSTRUCTIONS

Installation to be performed by a qualified technician.

### BRAKE KIT #

B4178WC &  
B4178WC2

### APPLICATIONS

1997-2004 C5 2014-2019 C7  
2005-2013 C6 Corvette & Z06

#### Important Notes

- B2795, B2796, & B2794A 11.25" steel rotors and two piece rotors have 0.312" minimal thickness.
- B5010 semi-metallic brake pads have 0.200" minimal thickness.
- Brake fittings do not come pre-installed, it will need a layer of Teflon sealer applied to the thread (Figure# 2 for torque specs)
- Modifications to the OEM upright are required (C7 on page 2, C5 & C6 on page 3)
- To use the provided upright modification for C5 & C6 template ensure printer settings are as follows. After clicking print in the PDF file go to the "Paper Handling" category. "Page Scaling" must be set changed from the default "Fit to Printable Area" option to "None." After printing ensure correct scale by measuring hub center to 3.61".
- Strange Engineering brake kits are designed for DRAG RACING ONLY!
- Also consult installation instructions for B1850 Strange Four Piston Directional Caliper kit.
- Wheel position will move out 0.500 from stock for B4178WC
- Wheel position will move out 0.625 from stock for B4178WC2

#### Before you begin installation

Consult factory service manual to remove and disassemble the upright and axle hub assembly.

Brake rotors are shipped with an oil film on surface to prevent rust and must be cleaned before installation.

Clean and inspect hub for damage (damaged wheel bearings, stripped threads, etc.) and repair or replace as needed.

Inspect upper and lower ball joints for excessive play and replace as needed.

Read these instructions thoroughly and save for future reference.

If after reading these installation instructions, you have any questions or comments, please do not hesitate to call us.

ALL KITS INCLUDE			
Item#	PART#	QTY	DESCRIPTION
2	B4178C	2	Brake Rotor Centering Spacer
3	B4178A	1	Brake Caliper Mount Driver Side
4	B1301E	4	3/8-24 Press Nut
5	B1301H	16	3/8 I.D. x 0.025 Thick Caliper Shim
6	B5004	1	Brake Caliper Driver Side
8	P2316	2	1/8 NPT x -3AN Fitting
9	B1301J	4	Caliper Bolt Washer
10	B5000Y	4	3/8-24 x 1.125" Caliper Mounting Bolt
11	B4178D	6	M12-1.75 x 65mm Hub Assembly Bolt
12	B4178B	1	Brake Caliper Mount Passenger Side
13	B5002	1	Brake Caliper Passenger Side
B4178WC ADDITIONAL PARTS			
1	B2796	1	Heavy Duty Brake Rotor Driver Side
7	B5010	4	Semi-metallic Brake Pads
14	B2795	1	Heavy Duty Brake Rotor Passenger Side
B4178WC2 ADDITIONAL PARTS			
7	B5010	4	Semi-metallic Brake Pads
15	B2794A	2	Two Piece Brake Rotor
16	B2794B	2	Two Piece Brake Rotor Adapter
17	B2794C	2	Two Piece Brake Rotor Spirolock

FIGURE # 1:

1. Perform required modifications to the OEM upright. See Figure #3 below for C7 modification and Figure #4 on the following page for modifications for C5 &6.
2. Refer to factory service manual to reassemble the upright to the front end.
3. Slide the caliper mount (3) and ABS Plate over the hub assembly. **Note:** ABS plate is optional.
4. Secure the hub assembly with the ABS plate and caliper mount (3) to the upright using the two hub assembly bolts (11) provided and single factory bolt. Ensure correct orientation of all parts. Torque the hub assembly bolts (11) to 85 ft-lbs.
5. Slide the rotor centering spacer (2) over the hub center. **Ensure register faces outboard.**  
**Note:** Remove any rust on mounting surfaces of hub. Lug nuts can be installed to avoid damaging wheel stud threads while cleaning the mounting surface.
6. Slide the rotor (1) or two piece rotor assembly (15,16,17) over the wheel studs flush to the face of the spacer (2). **Note:** Rotors mount with the arrow pointing in the direction of normal rotation. (Figure #1)
7. Attach the caliper (6) to the caliper mounting bracket (3) using the two caliper bolts (10) with red loctite, flat washers (9) and shims (5). Consult B1850 Strange Four Piston Caliper Kit instructions. Torque caliper bolts (10) to 35 ft-lbs.  
**Note:** The arrow on the caliper must face the normal rotation of the rotor/wheel. (See Figure #1) Determine the proper amount of shims by positioning the caliper as closely as possible to the center of the rotor.
8. Connect the hydraulic lines to the calipers. Calipers are tapped to 1/8"-27 NPT and supplied with -3AN fittings. Use proper adapters or use new -3AN braided steel line (teflon lined). Bleed the calipers with DOT 4 or DOT 5.1 brake fluid ONLY .  
A proper break-in procedure is required to avoid brake fade and uneven rotor deposits from the pads. It consists of 8-10 brake applications increasing in harshness while allowing the brakes to cool slightly in between; do not keep the brakes applied between stops. After the last stop the brakes should be allowed to cool completely.

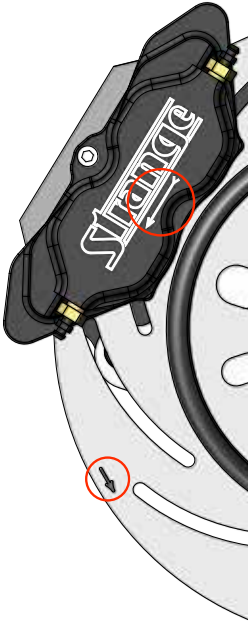
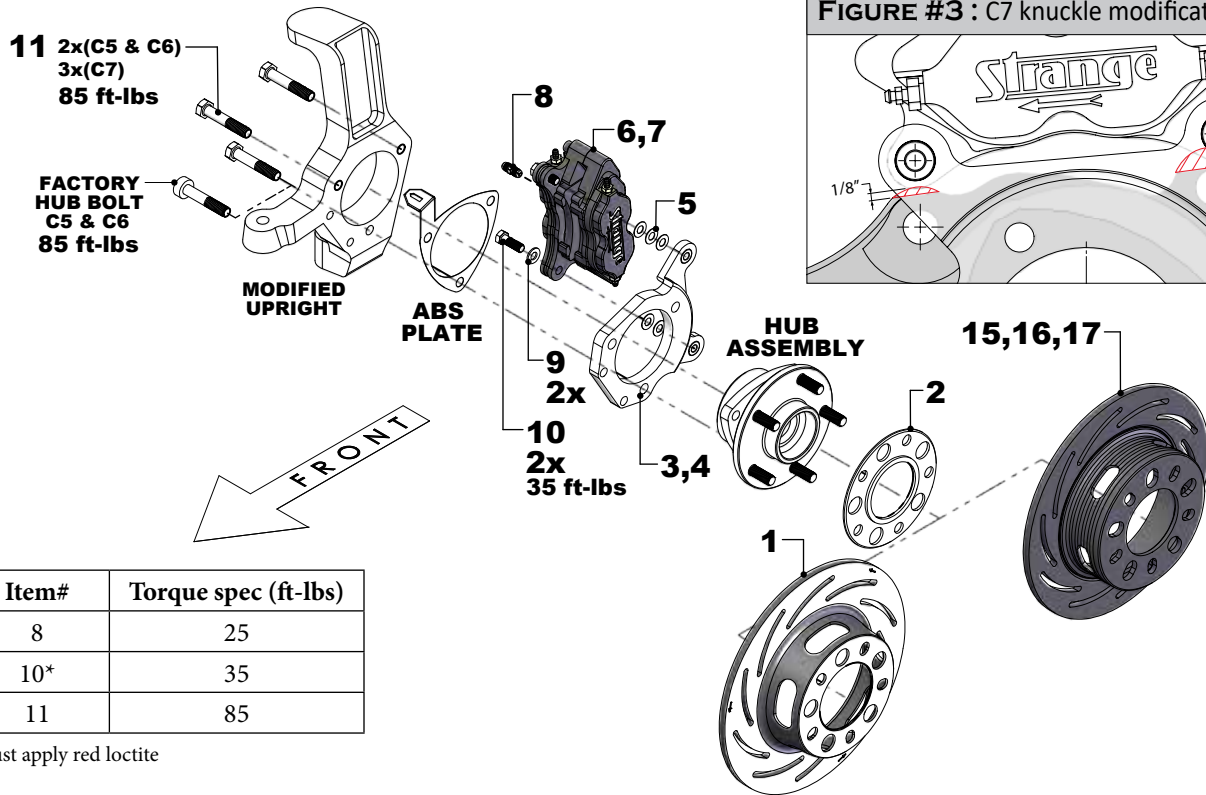

FIGURE # 2: Exploded view of B4178WC & B4178WC2



**FIGURE # 4:** C5&C6 knuckle modification. Can be used for driver or passenger side. Arrows must face correct orientation.

1. Glue template to a cardboard piece.
2. Cut out template and cardboard along dotted edges.  
-1/2" Drill bit can be used for the three hub assembly bolt cutouts.
3. Slide template thru hub assembly bolts and over hub center. Ensure arrows correspond to correct orientation.

