

**STRANGE DRAGSTER
/ ALTERED SPINDLES**

KIT #
S3453 (pair) - Dragster Spindle

APPLICATIONS
Dragsters - Utilizing Anglia style
spindle mount wheels

Before you begin installation:

- Read these instructions thoroughly and save them for future reference.
- If after reading these installation instructions you have any questions or comments, please do not hesitate to call us.

Features & Benefits:

- Heat treated chromoly spindle
- 7.5 degree king pin inclination
- Self lubricating DU bushings
- Optional brake kit is available, tabs must be welded onto the spindle to allow caliper to mount
- King pins bored and ported for lubricant delivery

KIT CONTENTS			
ITEM#	PART#	QTY	DESCRIPTION
1	S3453E	2	King pin
2	S3453D	2	Weld end
3	S3453F	2	Thrust washer
4	H1144B	2	1/4-28 Grease fitting
5	S3453I	2	5/16-24 X 1/4" Set screw
6	S3453B	2	Steering arm
7	S3453H	16	1/4-28 X 5/8" HHCS
8	S3453C	2	End cap
9	S3453G	4	DU 11DU08 Bushing
10	S3400L	2	3/32 x 1.25" Cotter pin
11	S3422L	2	5/8-18 Slotted half nut
12	S3453A	2	Dragster spindle

FIGURE # 1: Exploded S3453 Assembly View

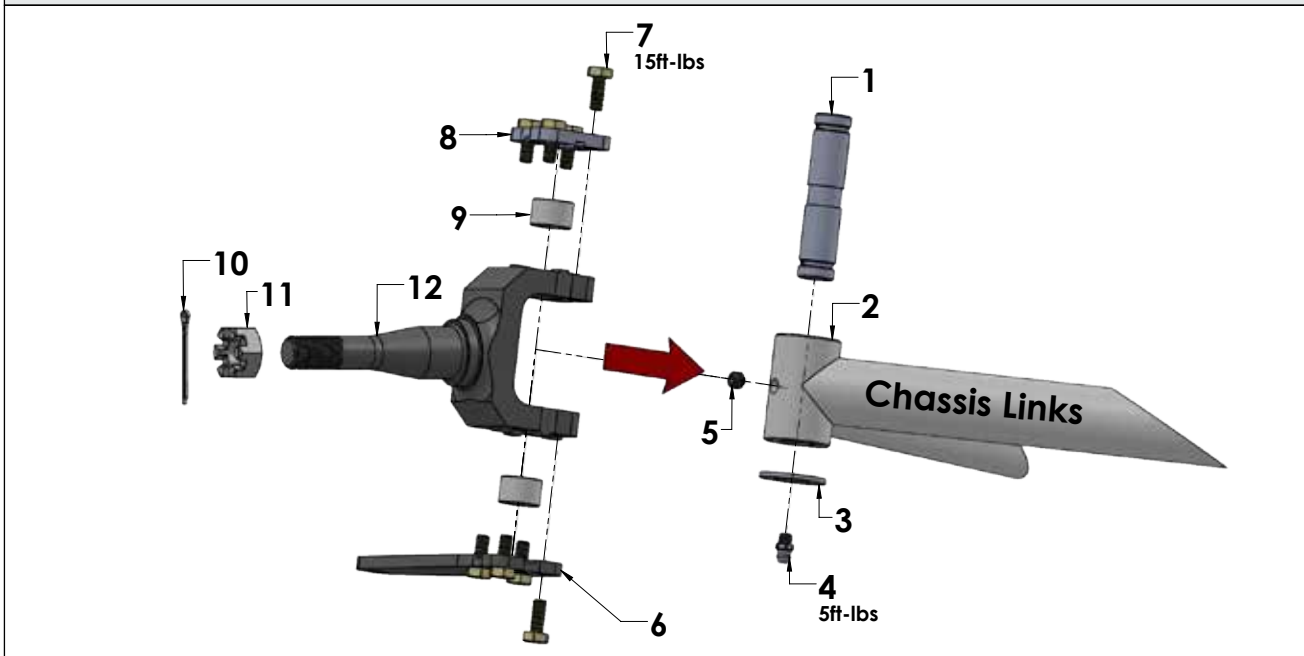
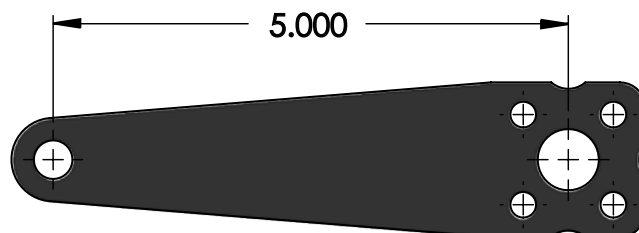

FIGURE # 2: Steering arm dimensions



Installation instructions

1. Dragster spindles (12) come with DU bushings (9) already pressed in.
2. Weld ends (2) must be welded to the chassis by a professional and qualified shop. Refer to welding information below.
3. After the welding is complete, thread the grease fitting (4) into the bottom of the king pin (1) and torque to 5 ft-lbs.
4. Position the dragster spindle (12) with the bushings (9) onto the weld end (2).
5. Place the thrust washer (3) between the bottom of the weld end (2) and the dragster spindle. Make sure both thrust washer and weld end are seated against the counterbores in the dragster spindle.
6. Slide the king pin assembly (1,4) through the top of the spindle.
7. Secure the king pin assembly with the bottom steering arm (6) and top end cap (8) using the HHCS (7) provided, 4 on each side torque to 15 ft-lbs.
8. Use the set screw (5) to secure the king pin firmly into the end well.

FIGURE # 2: Spindle bearing info

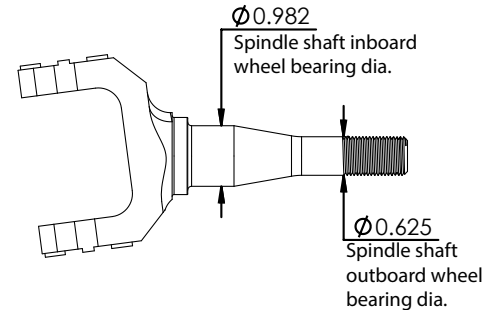

WELDING INFORMATION

- Use figures on the side for reference to the built in kingpin angle and the recommended caster angle.
- Weld end (3) is manufactured from 1018 CF steel.
- The recommended welding method by Strange Engineering is TIG welding using a mild steel rod.
- Before final welding the front end should be mocked up by tack welding the assembly together. Once proper alignment and steering geometry is verified completely weld the mating surfaces of the chassis links and weld end.

FIGURE # 3: Kingpin Angle

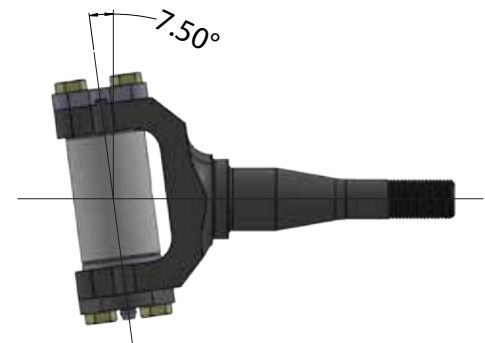

MAINTENANCE INFORMATION

- Maintenance includes a yearly inspection of wheel bearings and seals.
- General purpose grease such as white lithium can be used for spindle body and weld end bushings.
- Inspect for excessive play that may indicate worn DU bushings.
- Worn bushings must be replaced.

FIGURE # 4: Caster Angle

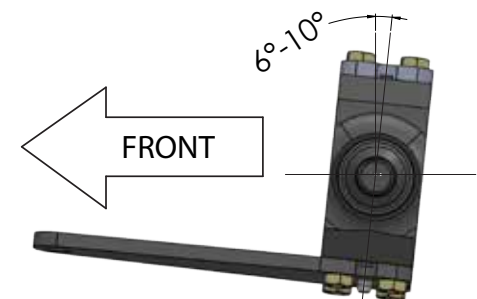

WARNING - RACING IS HAZARDOUS - STRANGE COMPONENTS ARE FOR LEGAL DRAG RACING ONLY

Disclaimer of Warranty - Purchasers using Strange Engineering racing components and equipment any and all inventory services, purchasers acknowledge that due to differing conditions and circumstances under which all equipment and parts are installed and used, purchasers are not relying on Strange Engineering Co. skill or judgment to select or furnish the proper part or equipment. Purchasers expressly affirm they are relying upon their own skill or judgment to select and purchase suitable goods. Strange Engineering Co. makes no warranties whatsoever, expressed or implied, oral or written, to purchasers. There is no warranty of merchantability made to purchasers. Strange Engineering Co., further excludes any implied warranty of fitness with respect to racing and equipment, any and all inventory and service.