

Strange

Kit Summary:

Kit #	B3370 (with remote reservoir)	B3370NR (w/out remote reservoir)
Rebuild Kit #	B3370R	
Description	Billet Aluminum Fast Fill Remote Master Cylinder	
Page	1 of 4 total pages	
Date Modified	Aug 26, 2021	

B3370 & B3370NR

ITEM#	PART#	QTY	DESCRIPTION
1	B3370A	1	Master Cylinder Body
2	B3362S	2	Banjo Bolt
3	B3362U	4	Aluminum Crush Washer
4	B3362T	2	Banjo Fitting (Outlet Ports)
5	P2356S	1	Front Brakes Reservoir Inlet Fitting
6	B3362Q	1	Rear Brakes Reservoir Inlet Fitting
7	B3362N	1	Inlet Fitting O-Ring
8	B3362HB	1	Valve Spring
9	Q1000C	1	3/16" Valve Ball
10	B3362HAS	1	Fast-fill Valve Assembly
11	B3362I	1	Pushrod Boot
12	B3362C	1	Pushrod

EXTERNAL RESERVOIR

ITEM#	PART#	QTY	DESCRIPTION
13	B3370E	1	Aluminum Reservoir Cap
14	B3370D	1	Primary Reservoir
15	B3363H	1	Secondary Reservoir
16	B3363K	1	1/4-20 Half Nut
17	B3363DC	1	Secondary Port Fitting
18	B3363D	1	Primary Port Fitting

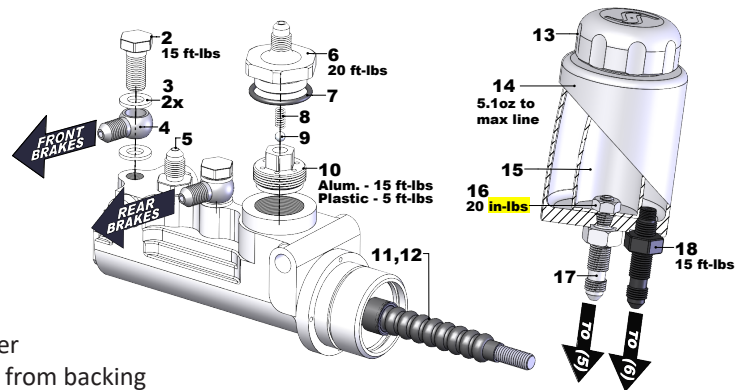

PLUMBING

- The reservoir, inlet, and outlet ports accept -3 AN fittings
- The outlet port closest to the push rod should be plumbed to the rear brakes
- The reservoir must be mounted above the level of the master cylinder and as far above the level of the calipers to stop fluid from backing up in the lines and pulling the caliper pistons back in their bores, eliminating the need for residual valves
- Bore dia. for the front brakes is 1-1/8" (front brake pressure will be half of the rear brake pressure)
- Bore dia. for the rear brakes is 7/8" (fast fill bore dia. is 1-1/8")

INSTALLATION

- Before installation, the master cylinder MUST be bench bled. The majority of soft or spongy brakes results from not bleeding the master cylinder before it is installed. To properly bench bleed the Master:
 1. Connect brakes lines from the reservoir to both inlet ports on the master cylinder
 2. Run brake lines from both outlet ports (4) to the inside of the reservoir
 3. Fill the reservoir with DOT 4 or DOT 5.1 brake fluid until the ends of the lines are covered (5.1oz)
 4. Slowly cycle the pushrod in and out until the lines are void of air
 - Recommended handle ratio is 10 to 1
 - After installation of the master cylinder, the brake system must be bled. Use only DOT 4 or DOT 5.1 brake fluid
- Note: During the bleeding process the reservoir cap MUST be left loose or completely off to let air into the reservoir as the fluid goes down. If the cap is left off, place a rag over the reservoir, as fluid may shoot up from the tank.

DIMENSIONS

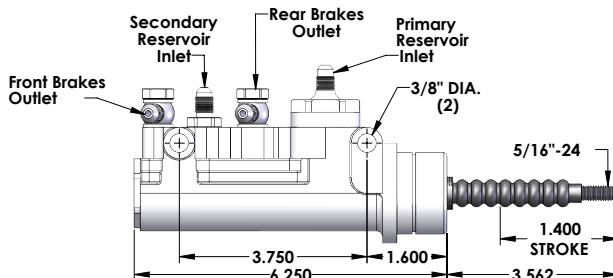
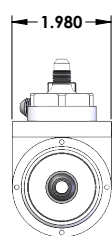

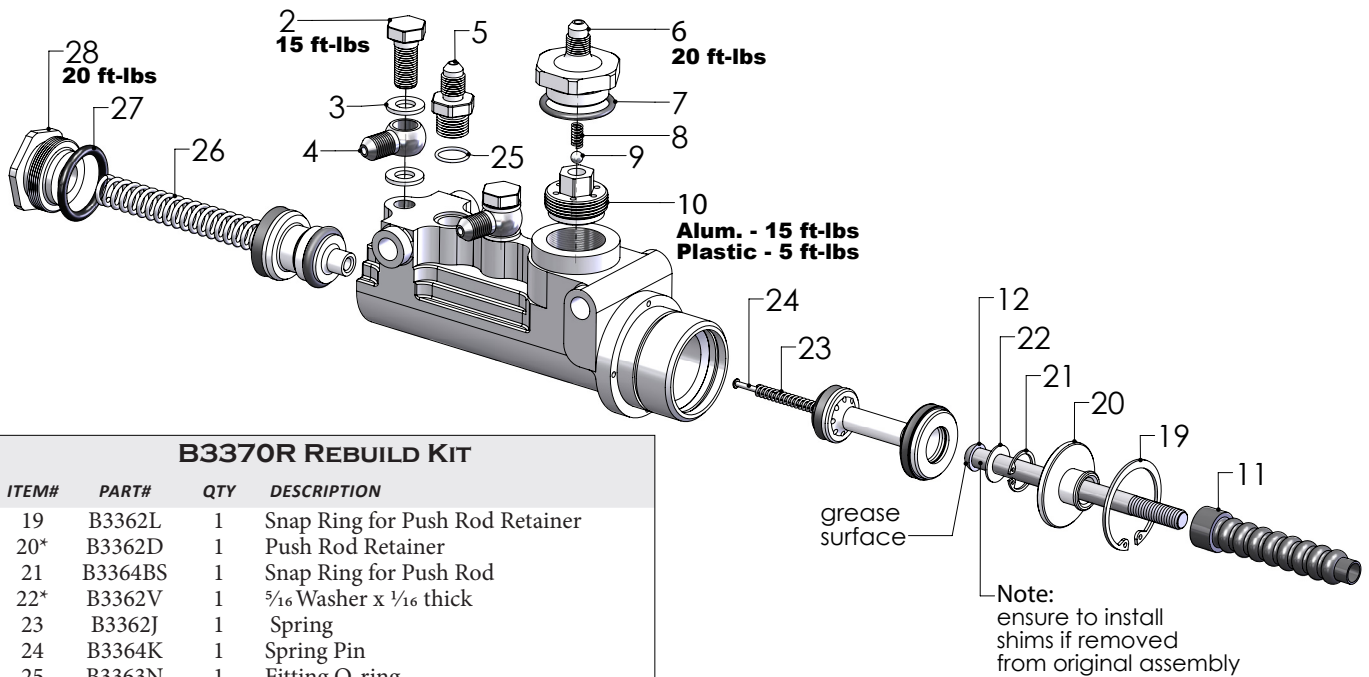

B3370R REBUILD KIT			
ITEM#	PART#	QTY	DESCRIPTION
19	B3362L	1	Snap Ring for Push Rod Retainer
20*	B3362D	1	Push Rod Retainer
21	B3364BS	1	Snap Ring for Push Rod
22*	B3362V	1	5/16 Washer x 1/16 thick
23	B3362J	1	Spring
24	B3364K	1	Spring Pin
25	B3363N	1	Fitting O-ring
26	B3351S	1	Spring Second Piston
27	B3364H	1	O-Ring #213
28*	B3364E	1	Plug

Note: items # marked * are not included in B3370R

DISASSEMBLY

- The following is required:
 - Hydraulic brake assembly lubricant (*Raybesto part # BAF12 or similar*)
 - Grease
 - Internal and external retaining-ring pliers
- The master cylinder should be hand stroked with all the ports facing away and into a container to remove as much of the remaining brake fluid out of the cylinder bores as possible.
 - Orient the unit in a vice with soft jaws and the plug (31) facing up. The plug must now be removed. When removing the plug (31), use a 1-1/4" wrench to only break off the initial torque. The plug should then be compressed by the palm of the hand while simultaneously rotating it counter clockwise. The spring (29) is compressed and will cause the plug to burst out rapidly if the plug is not compressed while being loosened.
 - Remove the spring (29). The secondary piston will still remain in the body. Place a rag over the surface which the plug (31) mated against to catch the excess fluid as the push rod is engaged to push the secondary piston out.
 - Remove the secondary piston assembly, pin (27) and spring (26). Remove the master cylinder from the vice.
 - Remove the pushrod boot (11). Remove the snap ring (22). The primary piston assembly can now be removed by retracting the push rod out of the master cylinder body.
 - Mount the unit horizontally in a vice and remove the inlet and outlet fittings and hardware. Remove the fast-fill valve assembly (10) and place aside for inspection. Ensure the 3/16" valve ball does not get lost during disassembly.
 - Disassemble the pushrod (12) from the primary piston by remove the snap ring (24).

Note: If push rod shims were installed between the washer (25) and primary piston the shims must be reused. The shims limit the amount of pushrod play and are not required for all assemblies depending on the manufacture date of the pushrods.

- Master cylinder bore inspection:

It's vital to inspect the master cylinder bores for wear, scoring and deposits. Discoloration or shiny spots in the bores are acceptable. Scoring should be felt by the finger. Generally, if the depth of a score catches the finger as it's glided across, the master cylinder body is not acceptable. Scotch brite paper can be used to gently scuff out any minor scores. Scores will cause fluid to seep past the cup seals and inadequate to no brake pressure to develop. If the master cylinder body is found to be unacceptable, please contact Strange Engineering. After inspection the master cylinder bores and body should be cleaned with brake cleaner and dried prior to reassembly.

PRIMARY PISTON ASSEMBLY

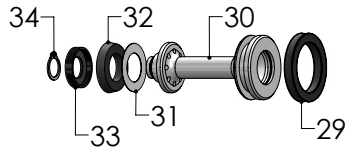

B3370R REBUILD KIT (CONT.)

ITEM#	PART#	QTY	DESCRIPTION
29	B3362O	1	Quad Ring
30	B3370B	1	Primary Piston
31	B3370X	1	Backup Washer
32	B3370K	1	3/8" Cup Seal
33	B3370G	1	3/8" Cup Seal Retainer
34	B3362M	1	Snap Ring for 3/8" Seal Retainer

- Primary piston inspection:

The primary piston needs to be inspected. The piston skirts and faces highlighted in red should be carefully inspected. If the push rod linkages are misaligned and the pushrod is being engaged at an angle, the piston is forced to rub against the master cylinder bore surfaces. This will result in shiny spots or in extreme cases deformation of the skirt towards the front of the piston. If there is evident damage of the piston skirts the master cylinder bore should be inspected. Furthermore, the brake linkages should be corrected so they're in line with the pushrod prior to master cylinder reinstallation.

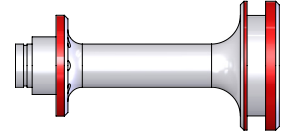

8. Replace items (32-37) on the new primary piston as shown above. Ensure the snap ring (37) seats fully in the groove.

SECONDARY PISTON

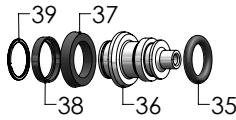

B3370R REBUILD KIT (CONT.)

ITEM#	PART#	QTY	DESCRIPTION
35	B3370I	1	O-ring #213
36*	B3370C	1	Secondary Piston
37	B3364F	1	1-3/8" Cup Seal
38*	B3364O	1	1-3/8" Cup Seal Retainer
39*	B3364P	1	Spirolox

Note: items # marked * are not included in B3370R

- Secondary piston inspection:

The secondary piston should be inspected for any damage prior to reassembly.

9. Replace items (38-42) on the secondary piston as shown above. Ensure the spirolox (42) seats fully in the groove.

FAST FILL VALVE INSPECTION

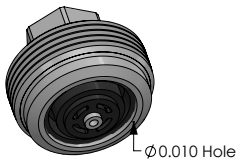

10. Aluminum fast-fill valves must be inspected prior to reinstallation. A blow gun should be used to clear it of any grit or debris. The 0.010 diameter hole should be clear of any debris or blockage. A 0.010 diameter drill bit can be used to clean out any debris if a blow gun does not work.

Note: do not reuse the indicated valves, only the yellow plastic and revised aluminum valves should be reused

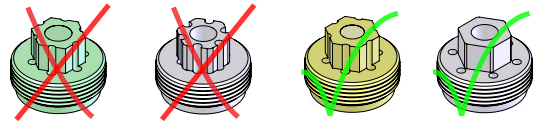

ASSEMBLY

10. Install the 3/16" washer (25) on the pushrod and secure the push rod to the primary piston with the snap ring (24).

Note: If shims were used between the pushrod and washer in the original assembly, reinstall prior to snap ring installation.

Ensure to apply grease on the push rod surface which mates against the primary piston.

11. Prior to installing the pistons in the master cylinder body, ensure to apply hydraulic brake assembly lubricant to all seals and o-rings. During reassembly, it might take a few attempts to slide the pistons in their respective bores as the o-rings will have slight resistance initially on a dry bore surface.

12. Slide the pushrod retainer (23) over the pushrod and piston assembly.

13. Install the primary piston with the pushrod assembly into the master cylinder body and secure with the snap ring (22) against the retainer (23). Ensure the snap ring seats properly in the groove.

14. Orient the master cylinder vertically in a vice with the pushrod facing down.

15. Slide the spring (26) into the primary piston from the rear of the master cylinder body and slide in the spring pin (27).

16. Pull the pushrod all the way down to retract the primary piston as much as possible. Then install the secondary piston assembly. Ensure the spring and pin (26, 27) properly engage into the secondary piston counter bore.

17. Place the spring (29) into the secondary piston.

18. Now the plug (31) must be reinstalled by compressing the spring by the palm of the hand while simultaneously rotating the plug (31) clockwise to engage into the threads. The plug should be initially installed by hand until it has securely caught enough threads. Then a 1-1/4" wrench can be used to torque the plug to 20 ft-lbs.

19. Reinstall both of the banjo fittings and bolts (2,4) with the new crush washers (3). Torque to 15 ft-lbs.

PISTON POSITION & INLET FITTING INSPECTION

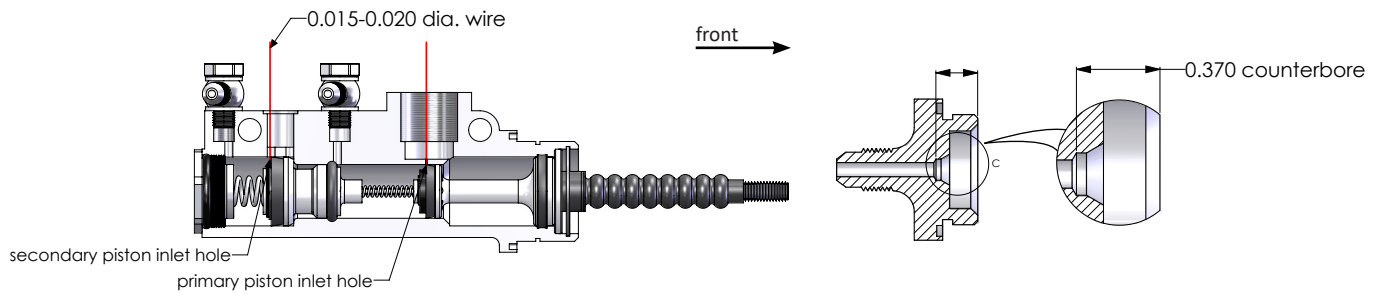

20. After internal component assembly the initial position of the pistons should be verified. This can be accomplished by using a 0.015-0.020 diameter wire. With the fast-fill valve still removed, slowly align and slide the wire straight into the primary piston inlet hole. The wire should slightly slip over the cup seal when force is applied and then hit the metal cup seal retainer which will prevent the wire from being fed in further. This ensures that minimal engagement of the pushrod will immediately begin creating brake pressure. If the wire slips in through the hole without resistance from the cup seal, this would indicate the piston is positioned too far to the front. The same test can be done on the secondary piston hole. If the wire cannot slide in at all because the hole is entirely blocked off by the cup seal then the master cylinder assembly needs to be rechecked. If the problem persists, please contact Strange Engineering.
21. Ensure the inlet fitting (6) has a 0.370 deep counter bore as shown above. This is required for all applications using the aluminum fast-fill valve. If using the yellow plastic fast fill valve the counter-bore depth does not need to be checked.
22. Now the fast-fill valve (10) can be installed and torqued to 20 ft-lbs. Next, install the valve ball (9) followed by the spring(8) and the inlet fitting (6) with the o-ring (7). A small rod can be slid through the inlet fitting (6) hole to guide the spring (8) into position.
23. Install the inlet fitting (5) with the o-ring (28).
24. The master cylinder should be bench bled prior to installation. Follow the guidelines on page 1.

Brake Fluid Breakdown

- Due to temperatures experienced during drag racing, DOT 4, DOT 5.1 or a high performance glycol based brake fluid is recommended.
- Brake systems are prone to moisture from humidity and regular use, therefore, moisture must be absorbed by the brake fluid instead of collected so the fluid does not easily boil.
- DOT 5 (silicone based) is not recommended. It does not mix with other fluids. It is slightly compressible giving soft pedal/handle. It also does not absorb water. When moisture enters the system, it settles at the lowest point in which most cases is the caliper. At braking temperatures moisture can boil causing a loss or lack of pedal/handle.
- Always perform a complete flush to the brake system when changing to a different brake fluid to avoid contamination.
- Do not use brake fluid from open bottles or bottles stored for long periods as moisture may have been absorbed.
- The dry boiling point is the temperature at which brake fluid will boil with no water (moisture) present in the system.
- The wet boiling point is the temperature at which brake fluid will boil when 3% is water by volume of the system.
- In race applications it's assumed brake fluid is changed often therefore moisture is not present and the dry boiling point can be a better reference when deciding on which fluid to use.

DOT 3	Dry Boiling Point °F	Wet Boiling Point °F
<ul style="list-style-type: none"> ↳ Inexpensive, readily available, mixes with DOT 4 and DOT 5.1 ↳ Lowest boiling point, absorbs water, eats paint 	400	285
<hr/>		
DOT 4		
<ul style="list-style-type: none"> ↳ Higher boiling point than DOT 3, absorbs water less readily than DOT 3 ↳ Absorbs water, eats paint 	445	310
<hr/>		
DOT 5		
<ul style="list-style-type: none"> ↳ Does not eat paint, high boiling point ↳ Does not mix with water, difficult to bleed 	500	355
<hr/>		
DOT 5.1		
<ul style="list-style-type: none"> ↳ High boiling point, mixes with DOT 3 & 4 ↳ Absorbs water, eats paint 	527	365