

**PRO SERIES 4-PISTON
REAR BRAKE KIT
INSTRUCTIONS**

KIT #
B1722WC
B1722WCM

APPLICATIONS
05-14 Mustang OEM Ends using
Strange Eliminator Kit

Before you begin installation

Brake rotors are shipped with an oil film on surface to prevent rust and must be cleaned before installation.
Brake fittings do not come pre-installed, it will need a layer of Teflon sealer applied to the thread (Figure#1 for torque specs)
Read these instructions thoroughly and save for future reference.
If after reading these installation instructions, you have any questions or comments, please do not hesitate to call us.

KIT CONTENTS				
ITEM#	PART#	QTY	DESCRIPTION	
1a	B2792	1	RH rotor	
1b	B2793	1	LH rotor	
2	A1098G	2	Caliper mount O-ring	
3	B1722A	2	05-14 Mustang caliper mount	
4	B1301E	4	Press Nut	
5	B1301H	16	0.025 Thick shim	
6a	B5002	1	Caliper RH	
6b	B5004	1	Caliper LH	
7a	B5010	4	Soft metallic 4-piston brake pad (B1722WC)	
7b	B5020	4	Hard metallic 4-piston brake pad (B1722WCM)	
8	P2316	2	-1/8 NPT fitting	
9	P2316C	2	Plastic Cap	
10	B1301J	4	Washer 3/8 ID	
11	B5000Y	4	3/8-24 x 1.125" HHCS	

FIGURE # 1: B1722WC Exploded view

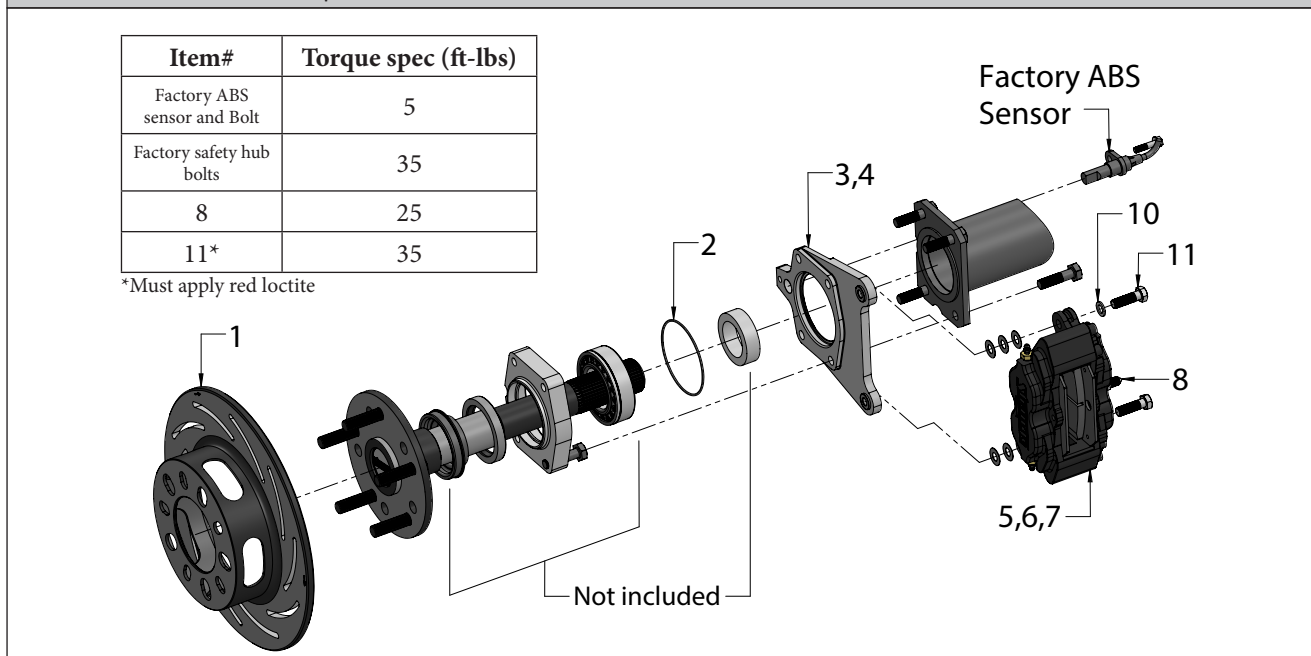

Installation instructions

FIGURE # 2:

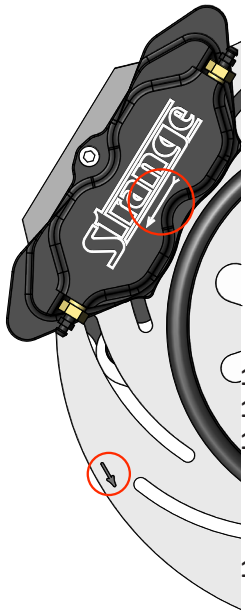

1. Remove wheel and tire, brake caliper and rotor.
2. Remove axle from the housing.
3. Unbolt the caliper bracket from the housing.
 - Note:** Wheel studs must be installed prior to installing optional reluctor rings (05-up Mustangs must reuse factory ring)
4. If applicable press the reluctor ring on the adapter. Ensure correct orientation as shown. (See Figure #3)
5. Press the reluctor ring assembly on the axle against the shoulder of the axle.
6. Press the safety hub assembly onto the axle. The side with the axle seal must face outboard.
 - Note:** Press only on the inner race of the bearing and ensure bearing seats fully against the spacer.
7. Press the wedding ring on the axle until it seats flush against the bearing.
8. Position the O-ring (2) over the outside diameter of the axle bearing and flush up against the safety hub.
9. Press the caliper mount (3) over the axle bearing with the stepped side facing inboard. Ensure to line up the ABS sensor holes in the bracket and safety hub outer half.
10. Apply a bead of RTV silicone between the housing end and inboard side of the caliper mount. (See Figure #4)
11. Install the four safety hub bolts and torque to 35 ft-lbs.
12. Install the factory ABS sensor and retaining bolt if applicable.
 - Slide the rotor (1) over the wheel studs and axle flange, ensuring that the rotor sits flat on the face of the axle flange.
 - Note:** Slotted rotors mount with the arrow pointing in the direction of normal rotation (See Figure #2).
 - Please read B1850 instructions for complete caliper instructions.
13. Attach caliper (6) with the arrow facing in the direction of normal rotor rotation using 3/8"-24 caliper bolts (11) with **red loctite** and 1/16" thick flat washers (10). Use 0.025" thick caliper shims (5) to center the caliper over the rotor, making sure pads contact the rotor evenly.
14. The caliper bolt (11) should be fully engaged into the press nut. If the bolt is over engaged, use any remaining shims under the head of the bolt to prevent it from running into the rotor. Torque the caliper mounting bolts (11) to 35 ft-lbs.
15. Connect the brake lines to the calipers. Calipers are tapped to 1/8"-27 NPT and supplied with -3AN fittings. Use proper adapters to connect them to existing lines or use new -3AN braided steel line (teflon lined). Bleed the calipers with DOT 4 or DOT 5.1 **ONLY** brake fluid.
16. A proper break in procedure is required to avoid brake fade and uneven rotor deposits from the pads. It consists of 8-10 brake applications increasing in harshness while allowing the brakes to cool slightly in between; do not keep the brakes applied between stops. After the last stop the brakes should be allowed to cool completely.

Note: After the initial installation of this kit, ensure that there is adequate clearance between all braking and chassis components by moving the suspension all the way up and down throughout its travel. Additionally, make sure that the brake lines are not interfering with the wheel travel, or subject to binding or kinking. Operate the vehicle in a cautious manner until you determine that the brakes are functioning properly. Routinely check and re-torque all bolts.

FIGURE # 3: Axle B-dimension

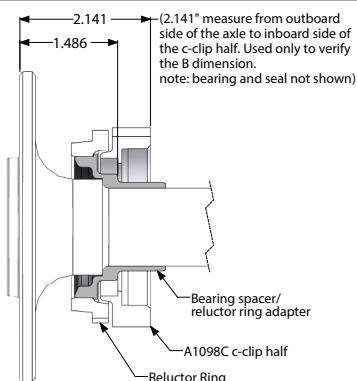
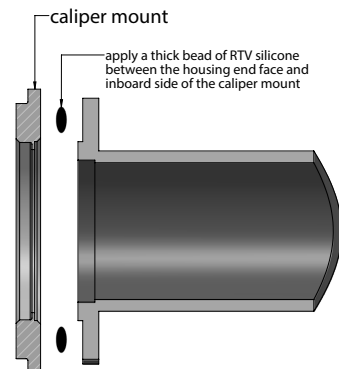

FIGURE # 4: Caliper mount RTV



WARNING – RACING IS HAZARDOUS · STRANGE BRAKES ARE FOR LEGAL DRAG RACING ONLY

Disclaimer of Warranty – Purchasers using Strange Engineering racing components and equipment any and all inventory services, purchasers acknowledge that due to differing conditions and circumstances under which all equipment and parts are installed and used, purchasers are not relying on Strange Engineering Co. skill or judgment to select or furnish the proper part or equipment. Purchasers expressly affirm they are relying upon their own skill or judgment to select and purchase Suitable goods.

Strange Engineering Co. makes no warranties whatsoever, expressed or implied, oral or written, to purchasers. There is no warranty of merchantability made to purchasers. Strange Engineering Co., further excludes any implied warranty of fitness with respect to racing and equipment, any and all inventory and service.