

# Strange

## HEAVY DUTY REAR BRAKE KIT INSTALLATION INSTRUCTIONS

Installation to be performed by a qualified technician.

### BRAKE KIT #

B1705WC, B1705WC2  
B1705WCM & B1705WCM2

### APPLICATIONS

1965-73 Mopar rear with  
H1147 housing end

### Important Notes

- B2792, B2793, & B2794A 11.25" steel rotors and two piece rotors have 0.312" minimal thickness
- B5010 semi-metallic and B5020 metallic brake pads have 0.200" minimal thickness
- Axle bearings should not be reused. A new axle bearing and wedging is required during this installation
- Strange Engineering brake kits are designed for drag racing only
- Also consult installation instructions for B1850 & B1855 Strange Four Piston Directional Caliper kit

### Before you begin installation

Brake rotors are shipped with an oil film on surface to prevent rust and must be cleaned before installation.  
Brake fittings do not come pre-installed, it will need a layer of Teflon sealer applied to the thread (Figure#2 for torque specs)  
Read these instructions thoroughly and save for future reference.  
If after reading these installation instructions, you have any questions or comments, please do not hesitate to call us.

### Brake kit offset

$$F = 2.500''$$

$$B = 2.250''$$

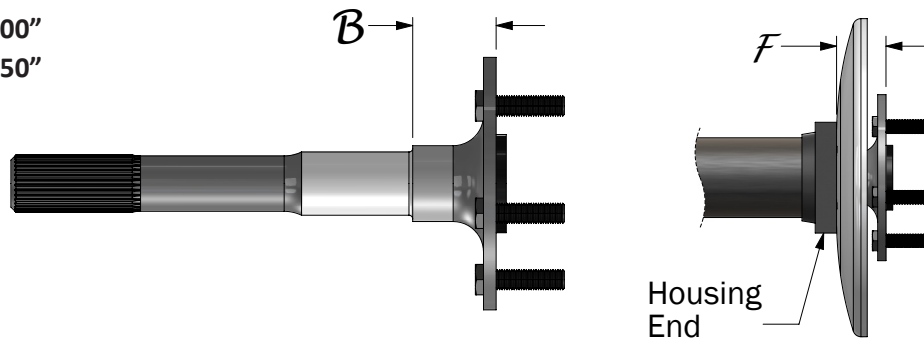

KIT CONTENTS			
ITEM#	PART#	QTY	DESCRIPTION
1	B1300H	10	3/8"-24 x 1-7/16" Tee Bolt
2a	B1705A	1	Brake Caliper Mount Rear LH
2b	B1705B	1	Brake Caliper Mount Rear RH
3	B1301E	4	3/8"-24 Press Nut
4	F1282	10	3/8"-24 Jet Nut
5a	B2793	1	Brake Rotor LH (B1705WC & B1705WCM kits only)
5b	B2792	1	Brake Rotor RH (B1705WC & B1705WCM kits only)
6	B2794	2	Two Piece Steel Rotor (B1705WC2 & B1705WCM2 kits only)
7	B5000Y	4	3/8"-24 x 1-1/8" Caliper Mounting Bolt (included with B1850 & B1855)
8	B1301J	4	1/16" Thick Caliper Washer (included with B1850 & B1855)
9	B1301H	16	0.025" Thick Caliper Shims (included with B1850 & B1855)
10	B1850	1	Four Piston Caliper Kit Semi-Metallic Pads (B1705WC & B1705WC2 kits only)
11	B1855	1	Four Piston Caliper Kit Metallic Pads (B1705WCM & B1705WCM2 kits only)
12	P2316	2	1/8" NPT x -3AN Fitting

WARNING - RACING IS HAZARDOUS · STRANGE BRAKES ARE FOR LEGAL DRAG RACING ONLY

Disclaimer of Warranty - Purchasers using Strange Engineering racing components and equipment any and all inventory services, purchasers acknowledge that due to differing conditions and circumstances under which all equipment and parts are installed and used, purchasers are not relying on Strange Engineering Co. skill or judgment to select or furnish the proper part or equipment. Purchasers expressly affirm they are relying upon their own skill or judgment to select and purchase suitable goods.

Strange Engineering Co. makes no warranties whatsoever, expressed or implied, oral or written, to purchasers. There is no warranty of merchantability made to purchasers. Strange Engineering Co., further excludes any implied warranty of fitness with respect to racing and equipment, any and all inventory and service.

FIGURE # 1:

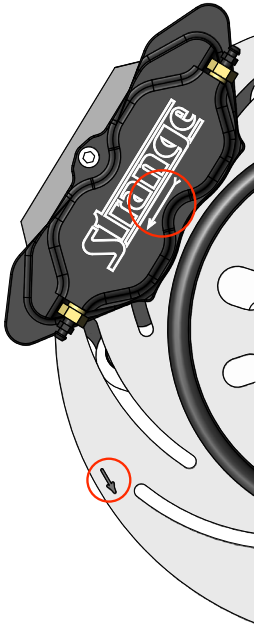

1. Raise and support rear of vehicle on a level surface using suitable equipment.
2. Refer to factory service manual to disassemble the factory rear brakes.
3. Remove bearing, wedding ring, and bearing retaining plate from axle and discard all three.
4. Check the axle for any signs of twisting or run out and replace as needed.
5. Inspect the rotor (5 or 6) for proper fitment on the axle flange.  
**Note:** If the axle flange diameter is too large it should be machined down to 6.240" diameter.  
If using factory axles ensure wheel studs do not interfere with rotor installation.
6. Inspect the housing end for straightness and repair as needed.
7. Replace housing end studs with tee bolts (1).
8. Slide the caliper mounting bracket (2,3) on the axle with the press nuts facing outboard.
9. Install a new bearing on the axle. Press only on the inner race of the bearing. Ensure the seal faces outboard. Use a small amount of oil to the inside diameter of the bearing to aid with installation. Ensure the bearing fully seats against the axle step.
10. Press the wedding ring on the axle until it seats fully against the bearing.
11. Install the axle into the housing until the bearing bottoms out in the housing end.
12. Slide the caliper mounting bracket (2,3) over the t-bolts (1).
13. Install the jet nuts (4) and torque to 35 ft-lbs.
14. Slide the brake rotor (5 or 6) over the wheel studs and axle flange, ensuring the rotor seats flat against the face of the axle flange.  
**Note:** Slotted rotors and caliper kits mount with the arrow pointing in the direction of normal rotation (see figure 1).
15. Please read B1850 or B1855 instructions for complete caliper and brake line installation. The proper brake pad and rotor bed-in procedure outlined in B1850 & B1855 instructions must be performed to avoid premature brake fade.  
**Note:** Only two caliper shims (9) should be required per caliper ear to center the caliper between the rotor.

FIGURE # 2: Exploded view of B1705WC

