

# Strange

**PRO SERIES 4-PISTON  
REAR BRAKE KIT  
INSTRUCTIONS**

**KIT #**  
B1718WC  
B1718WCM

**APPLICATIONS**

Rear brake kit for Strange 3.150" Small GM housing ends H1143

\* Is not compatible with Moser GM housing end Part# 7900  
-Moser flush mount GM ends part# 7900FM can be used with either B1105G (tapered bearing spacer) or B1105GB (ball bearing spacer).

**Before you begin installation:**

- Strange Engineering brake kits are designed for DRAG RACING ONLY!
- See instructions for A1030 for safely hub installation.
- Read these instructions thoroughly and save for future reference.
- If after reading these installation instructions, you have any questions or comments, please do not hesitate to call us.

**KIT CONTENTS**

ITEM#	PART#	QTY	DESCRIPTION
1	B2792	1	HD Slotted Right-Hand Rotor
-	B2793	1	HD Slotted Left-Hand Rotor
2	B1300H	8	3/8"-24 x 1-1/4 Tee Bolt
3	B1301E	4	3/8"-24 Press nut (Installed in B1718A/B)
4a	B1718A	1	Caliper mounting bracket (Right)
4b	B1718B	1	Caliper Mounting Bracket (Left)
5	F1282	8	3/8"-24 "Jet" nut
6	B1301H	16	0.025" Thick caliper shim
7	B1301J	4	1/16" Thick caliper washer
8	B5000Y	4	3/8"-24 x 1-1/8" Caliper bolt
9a	B5010	4	Soft 4-piston brake pad (B1718WC)
9b	B5020	4	Hard metallic 4-piston brake pad (B1718WCM)
10	B5002	1	Right-Hand 4 piston caliper
-	B5004	1	Left-Hand 4 piston caliper
11	P2316	2	1/8" NPT x -3AN Fitting (Installed in B5002 & B5004)

**FIGURE # 1: Exploded B1718WC Assembly View**

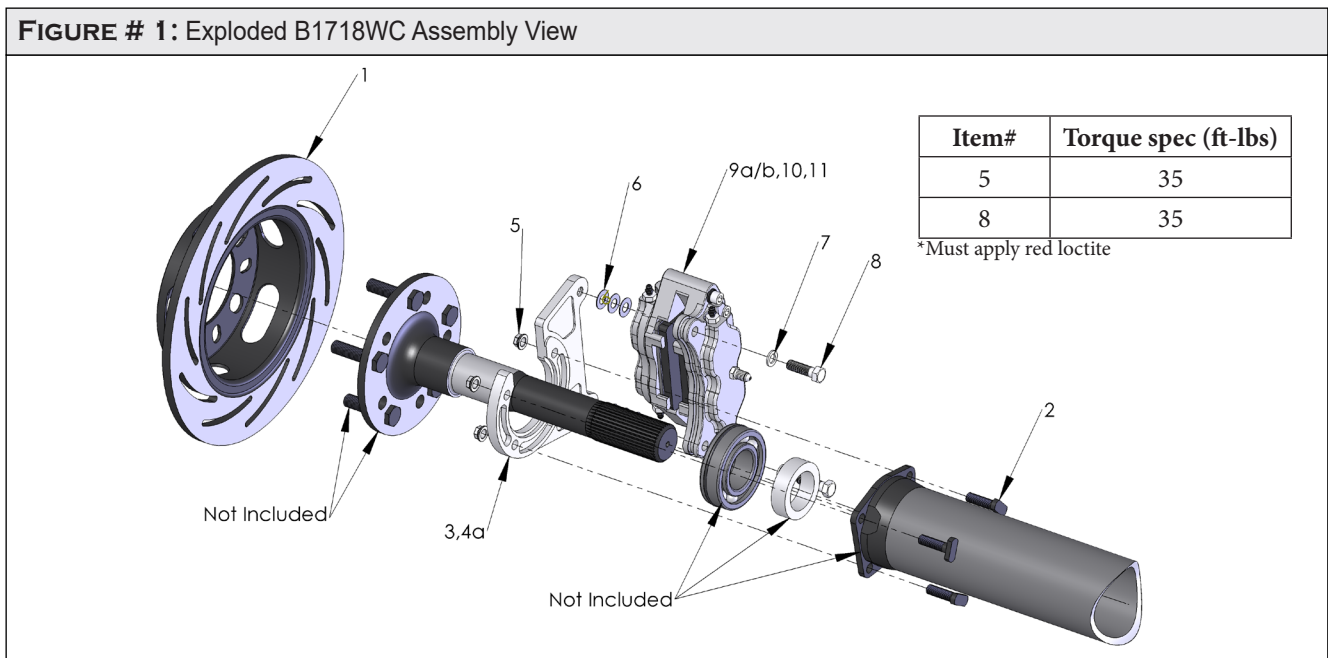

### Installation instructions

**Figure # 2**

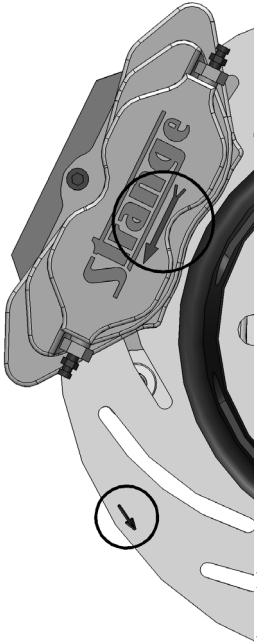

1. Raise and support rear of vehicle on a level surface using suitable equipment.
2. Remove wheel, axle, and current brakes.  
**Note:** With the B1718WC and B1718WCM kits, the slot in the bracket may enable you to install this kit without pulling the bearing and wedding ring from the axle. If you can remove your current brake setup without having to pull the bearings, inspect the bearing for signs of wear. If the bearing does not need to be replaced, then skip steps 3,5 & 6.
3. Remove bearing, wedding ring, and caliper mount from axle
4. Check the axle for any signs of twisting or runout and repair or replace as needed. The maximum allowable runout checked between centers at the face of the flange, bearing surface, and near the splines is 0.005" total indicated runout (T.I.R.).
5. Install a new bearing (not included) on the axle, pressing only on the inner race making sure the seal faces the axle flange. Before installing, apply a small amount of oil to the I.D. of the bearing to aid in installation. Make certain that the bearing fully seats against the step on the axle.
6. Press the wedding ring onto the axle until it seats flush against the bearing.
7. Slide the axle into the housing until the bearing bottoms out in the housing end.
8. Inspect the rotor (1) for fit on the axle flange. The rotor should slide freely over the axle flange and seat flush against the face of the axle flange. The rotor must center on the axle flange or axle studs. If the axle flange is too large, it must be machined to 6.240" diameter.
9. Inspect the housing end for straightness and repair as necessary.
10. Slide the caliper mounting bracket (4) on the axle with the press nuts (3) facing the axle flange. The bracket can be mounted facing the front of the car or towards the rear of the car.
11. Install the housing end bolts (2) with the jet nuts (5) and torque to 35 ft-lbs.
12. Slide the rotor (1) over the wheel studs and axle flange, ensuring that the rotor sits flat on the face of the axle flange.  
**Note:** Slotted rotors mount with the arrow pointing in the direction of normal rotation (See Figure #2).  
 - Please read B1850 instructions for complete caliper instructions.
13. Attach caliper (10) with the arrow facing in the direction of normal rotor rotation using 3/8"-24 caliper bolts (8) with **red loctite** and 1/16" thick flat washers (7). Use 0.025" thick caliper shims (6) to center the caliper over the rotor, making sure pads contact the rotor evenly. The caliper bolt (8) should be fully engaged into the press nut. If the bolt is over engaged, use any remaining shims under the head of the bolt to prevent it from running into the rotor. Torque the caliper mounting bolts (8) to 35 ft-lbs.
14. Connect the brake lines to the calipers. Calipers are tapped to 1/8"-27 NPT and supplied with -3AN fittings. Use proper adapters to connect them to existing lines or use new -3AN braided steel line (teflon lined). Bleed the calipers with DOT 4 or DOT 5.1 brake fluid ONLY.
15. A proper break in procedure is required to avoid brake fade and uneven rotor deposits from the pads. It consists of 8-10 brake applications increasing in harshness while allowing the brakes to cool slightly in between; do not keep the brakes applied between stops. After the last stop the brakes should be allowed to cool completely.

**Note:** After the initial installation of this kit, ensure that there is adequate clearance between all braking and chassis components by moving the suspension all the way up and down throughout its travel. Additionally, make sure that the brake lines are not interfering with the wheel travel, or subject to binding or kinking. Operate the vehicle in a cautious manner until you determine that the brakes are functioning properly. Routinely check and re-torque all bolts.

#### **WARNING – RACING IS HAZARDOUS · STRANGE BRAKES ARE FOR LEGAL DRAG RACING ONLY**

**Disclaimer of Warranty – Purchasers using Strange Engineering racing components and equipment any and all inventory services, purchasers acknowledge that due to differing conditions and circumstances under which all equipment and parts are installed and used, purchasers are not relying on Strange Engineering Co. skill or judgment to select or furnish the proper part or equipment. Purchasers expressly affirm they are relying upon their own skill or judgment to select and purchase suitable goods.**

**Strange Engineering Co. makes no warranties whatsoever, expressed or implied, oral or written, to purchasers. There is no warranty of merchantability made to purchasers. Strange Engineering Co., further excludes any implied warranty of fitness with respect to racing and equipment, any and all inventory and service.**