

## INSTALLATION INSTRUCTIONS STRANGE SPORTSMAN 11" REAR CARBON BRAKE KIT

**KIT #**  
C1200WC

**APPLICATIONS**  
Full Floater Axle Assembly  
w/ 5.50" Bolt Circle

### Before you begin installation:

Refer to Ultra Caliper instructions for caliper installation and carbon brake notes  
Strange Engineering brake kits are designed for DRAG RACING ONLY  
Spanner wrench part# F1294 is required for this installation. (step 12)

ITEM #	PART #	QTY	DESCRIPTION
1	B5000X	4	3/8-24 x 1.27" Caliper Mounting Bolt
2	B5040	2	Ultra Brake Caliper
3	L4050H	4	Soft Carbon Brake Pads
4	B1301H	16	3/8 I.D. x 0.025" Thick Caliper Shim
5	C1200A	2	FFAA Carbon Caliper Mounting Bracket
6	B1301E	4	3/8-24 Press Nuts
7	F3100C	2	FFAA Carbon Rotor Adapter
8	C1790	2	Carbon Rotor 11"
9	C1700H	2	Retainer Ring
10	C1700D	20	1/4-20 x 1/2" FHSCS

FIGURE # 1: Exploded B1200WC Assembly View

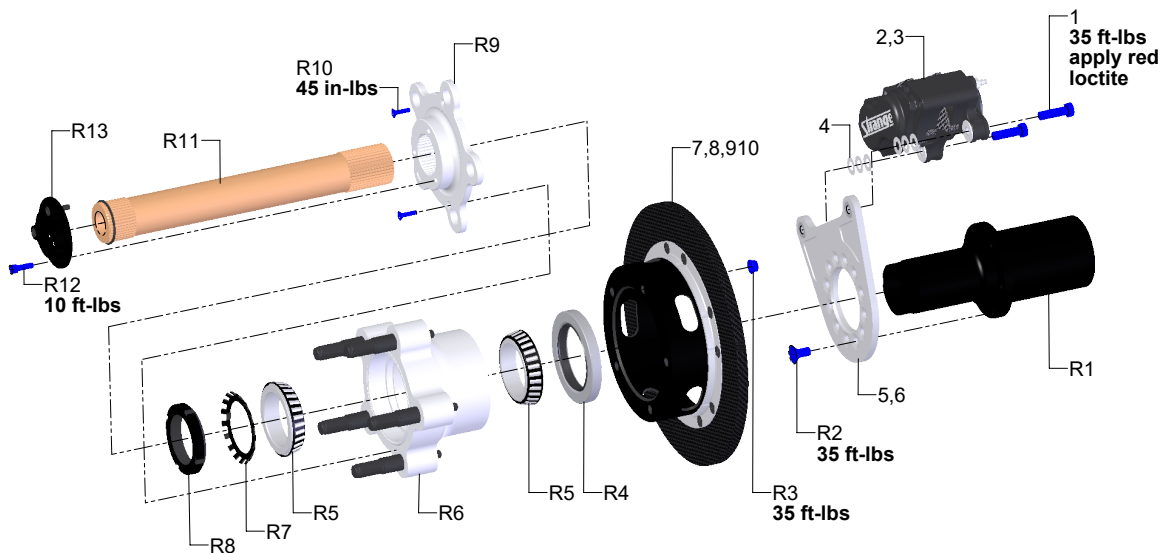

### Important Notes

- Carbon brake pads (L4050HS) minimal thickness is 0.200"
- 11" Carbon rotors (C1790) minimum thickness is 0.300"
- Rotors wear concave and pads wear convex; therefore, measure rotor thickness in the middle of the rotor and pad thickness in the area where there are no piston
- Rear Carbon Brakes perform best with caliper pressure from 1,100-1,200 psi

## INSTALLATION INSTRUCTIONS STRANGE SPORTSMAN 11" REAR CARBON BRAKE KIT

**KIT #**  
C1200WC

**APPLICATIONS**  
Full Floater Axle Assembly  
w/ 5.50" Bolt Circle

1. Raise and support rear of vehicle on a level surface using suitable equipment.
  2. Remove wheel, driveplate and axle assembly, spindle nut and lock, and hub assembly.
  3. Remove the existing brake bracket from spindle.
  4. Disassemble the existing rotor assembly from the hub assembly by removing the five "jet" nuts (R3) from the back of the rotor.
  5. Install the new carbon rotor assembly (7,8,9,10) onto the hub.
 

**Note:** The carbon rotor assembly is pre-assembled. (Figure 2)  
If ever disassembled ensure proper torque spec. The carbon rotor large counterbore must face **outboard** or failure will occur. (Figure 2)
  6. Install the carbon caliper bracket (5) on the spindle using the six pre-existing caliper mounting bolts (R2). Ensure the press nuts (6) face **OUTBOARD**. Torque to 35 ft-lbs.
 

**Note:** The caliper bracket can be clocked in 12 different positions.
  7. Inspect the inner and outer hub bearings (R5) and replace and/or re-pack as necessary. If re-packing, use a high quality wheel bearing grease such as NLGI #1 or #2.
 

**Note:** A bearing packer is recommended for this procedure. However, if one is not available, work as much grease as possible into the cage and around the rollers by hand.
  8. Place a hub bearing (R5) in the inboard side of the floater hub (R6).
  9. Press the hub seal (R4) into the inboard side of the floater hub (R6) flush to the face of the hub.
 

**Note:** Ensure that the face on the oil seal (R4) stamped with the part# faces the outside of the hub.
  10. Slide the hub assembly onto the spindle, then slide the outer hub bearing (R5) into the hub.
  11. Slide the spindle nut lock (R7) over the spindle aligning the tang with the groove in the spindle.
  12. Thread the spindle nut (R8) onto the spindle ensuring that the large bevel on the nut faces **INBOARD**. Torque to 20 ft-lbs
 

**Note:** Spanner wrench part # F1294, is required. Rotate the hub several times to make sure everything is seated properly.  
**IMPORTANT:** Do not run the vehicle with the spindle nut torqued to 20 ft-lbs. Bearing damage will result. Loosen spindle nut until the hub spins freely and no end play exists. Bend one tab of the spindle nut lock (R7) into one of the four slots that correspond the closest in the spindle nut (R8).
  13. Install the driveplate (R9) onto the floater hub using the two existing 10-24 x 3/4" driveplate screws (R10). Torque to 45 in-lbs.
  14. Slide the existing floater axle (R11) through the driveplate (R9) until the spirolock on the axle sits flush on the driveplate.
  15. Install the driveplate cap (R12) using the three existing 1/4"-28 x 3/4" bolts (R12). Torque to 10 ft-lbs.
 

- **Please read instructions for complete Ultra Caliper instructions.**
  16. Attach caliper (2) using caliper bolts (1) with red loctite. Use 0.025" thick caliper shims (4) to center the caliper over the rotor, making sure pads contact the rotor evenly. If the bolt is over engaged, use any remaining shims under the head of the bolt to prevent it from running into the rotor. Torque the caliper bolts (1) to 35 ft-lbs.
  17. Connect the brake lines to the calipers. Calipers are tapped to 1/8"-27 NPT and supplied with -3AN fittings. Use proper adapters to connect them to existing lines or use new -3AN braided steel line (teflon lined). Bleed the calipers with DOT 4 or DOT 5.1 brake fluid **ONLY**.
  18. Install the wheels, wheel washers and lug nuts. Consult the wheel manufacturer instructions for lug nut torque specs.
- Note:** After the initial installation, ensure there is adequate clearance between all braking and chassis components by moving the suspension all the way up and down throughout its travel. Additionally, ensure the brake lines are not subject to binding or kinking. Operate the vehicle in a cautious manner until you determine that the brakes are functioning properly. Check and re-torque all bolts before every event.

**FIGURE # 2:** Exploded B1200WC Assembly View

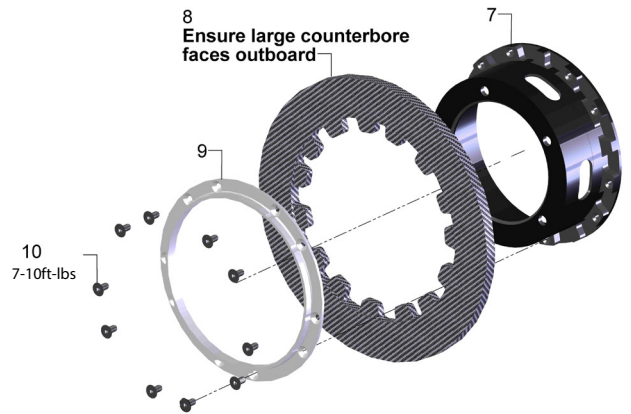

### WARNING – RACING IS HAZARDOUS

Disclaimer of Warranty – Purchasers using Strange Engineering racing components and equipment any and all inventory services, purchasers acknowledge that due to differing conditions and circumstances under which all equipment and parts are installed and used, purchasers are not relying on Strange Engineering Co. skill or judgment to select or furnish the proper part or equipment. Purchasers expressly affirm they are relying upon their own skill or judgment to select and purchase suitable goods. Strange Engineering Co. makes no warranties whatsoever, expressed or implied, oral or written, to purchasers. There is no warranty of merchantability made to purchasers. Strange Engineering Co., further excludes any implied warranty of fitness with respect to racing and equipment, any and all inventory and service.