

Strange

Page 1 of 3

Dec 1, 2020

PRO SERIES 4-PISTON REAR BRAKE KIT INSTRUCTIONS

KIT #
B1723WC2 - Mustang GT

APPLICATIONS
15" - 20" Mustang GT
- Call for GT350 applications
- Does not fit AED Drag race knuckle

Important Notes

- B2794A 11.25" steel rotors and two piece rotors have 0.312" minimal thickness
- B5010 semi-metallic brake pads have 0.200" minimal thickness
- Strange Engineering brake kits are designed for drag racing only
- Also consult installation instructions for B1850 Strange Four Piston Directional Caliper kit

Before you begin installation

Brake rotors are shipped with an oil film on surface to prevent rust and must be cleaned before installation. Read these instructions thoroughly and save for future reference.

If after reading these installation instructions, you have any questions or comments, please do not hesitate to call us.

KIT CONTENTS

ITEM#	PART#	QTY	DESCRIPTION
1	B2794BB	2	2 piece rotor adapter 1.800"
2	B2794A	2	2 piece rear rotor
3	B2794D	2	2 piece rotor spirolok VHM-180
4	B4148C	4	3/8-16 x 1" FHSCS
5	B1723C	4	3/8-16 x 2-1/2 FHSCS
6a	B1723AL	1	15-18 Mustang LH caliper mount
6b	B1723AR	1	15-18 Mustang RH caliper mount
7	B1301E	4	3/8-24 Press Nut
8	B1723B	4	15-18 Mustang GT caliper mount spacer
9	B3359Q	4	3/8-16 locknut
10	B1301H	16	3/8 ID x 0.25 Thick Shim
11	B5002	1	Caliper RH
12	B5004	1	Caliper LH
13	B5010	4	Soft pad
14	P2316C	2	Plastic cap
15	P2322	2	#3 x 1/8 NPT -90
16	B1301J	8	Washer 3/8 ID 1/16 Thick flat
17	B5000Y	4	3/8-24 x 1.125" HHCS

WARNING - RACING IS HAZARDOUS · STRANGE BRAKES ARE FOR LEGAL DRAG RACING ONLY

Disclaimer of Warranty - Purchasers using Strange Engineering racing components and equipment any and all inventory services, purchasers acknowledge that due to differing conditions and circumstances under which all equipment and parts are installed and used, purchasers are not relying on Strange Engineering Co. skill or judgment to select or furnish the proper part or equipment. Purchasers expressly affirm they are relying upon their own skill or judgment to select and purchase suitable goods.

Strange Engineering Co. makes no warranties whatsoever, expressed or implied, oral or written, to purchasers. There is no warranty of merchantability made to purchasers. Strange Engineering Co., further excludes any implied warranty of fitness with respect to racing and equipment, any and all inventory and service.

Installation instructions

FIGURE # 1:

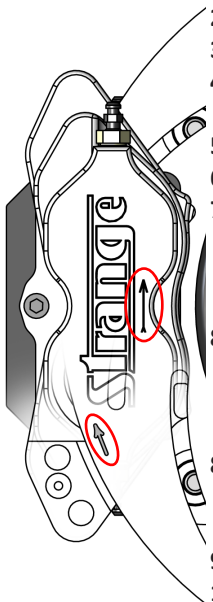

1. Raise and support front of vehicle on a level surface using suitable equipment.
 2. Remove wheel, stock disc, hub, brake line, and caliper assembly from knuckle.
 3. Place caliper mount spacers (8) in existing caliper holes.
 4. Install the caliper mount (6) using both sets of caliper bracket bolts (4) used in the modified holes torqued to 30 ft-lbs and (5) in the holes using the caliper mount spacers (8).
 5. Torque the longer caliper bracket bolts (5) with washer (16) and locknuts (9) to 30 ft-lbs.
 6. Mount the hub onto the knuckle using the existing hub screws.
 7. Assemble the hat (1), rotor (2) and spirolock (3). Slide it over the wheel studs and make sure it sits flush with the hub face.
- Note:** Slotted rotors and caliper kits mount with the arrow pointing in the direction of normal rotation (see figure 1).
8. Attach caliper (11, 12) with the arrow facing in the direction of normal rotor rotation using 3/8"-24 caliper bolts (17) with red loctite and 3/8" I.D. flat washers (16). Use 3/8" I.D. caliper shims (10) to center the caliper over the rotor, making sure pads contact the rotor evenly. Use any remaining shims under the head of the 3/8" Dia. caliper bolt to prevent the bolt from contacting the rotor. Torque the caliper mounting bolts (17) to 35 ft-lbs.
 9. Connect the hydraulic lines to the calipers. Calipers are tapped to 1/8"-27 NPT and supplied with -3AN fittings. Use proper adapters to connect them to existing lines or use new -3AN braided steel line (teflon lined). Bleed the calipers with DOT 4 or DOT 5.1 brake fluid ONLY.
 10. Mount the wheel and tire assembly on the hub and snug the lug nuts.

A proper break in procedure is required to avoid brake fade and uneven rotor deposits from the pads. It consists of 8-10 brake applications increasing in harshness while allowing the brakes to cool slightly in between; do not keep the brakes applied between stops. After the last stop the brakes should be allowed to cool completely.

FIGURE # 2: B1723WC2 Knuckle Modification

FIGURE # 3: B1723WC2 Exploded view (Driver's side)

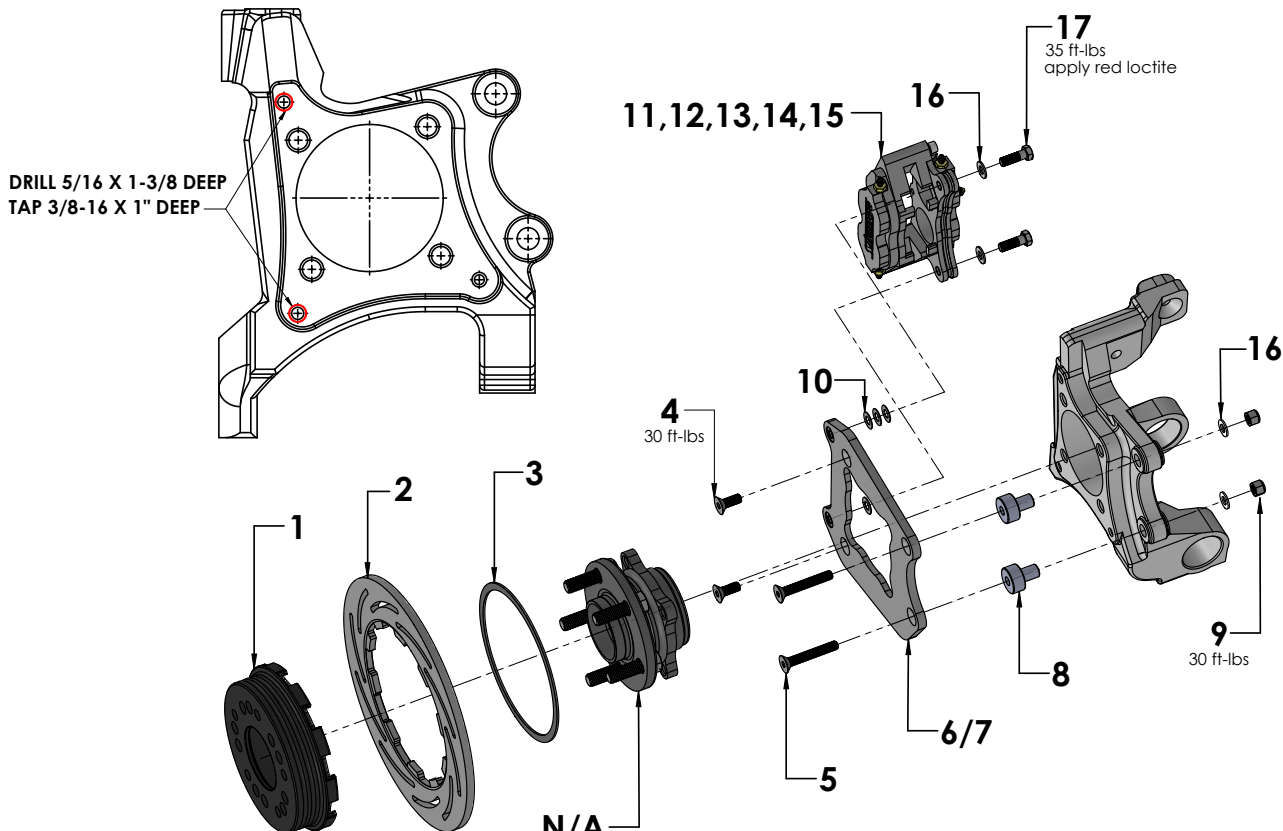

Wheel Clearance dimensions

