

Strange

DUAL 4-PISTON REAR BRAKE KIT INSTRUCTIONS

KIT #
B1711WCD - Symmetrical
housing ends

APPLICATIONS
Symmetrical 3.350" housing end
with Brake offset = 2.832"

Before you begin installation:

-Strange Engineering brake kits are designed for DRAG RACING ONLY!

-Read these instructions thoroughly and save for future reference.

-If after reading these installation instructions, you have any questions or comments, please do not hesitate to call us.

KIT CONTENTS

ITEM#	PART#	QTY	DESCRIPTION
1	L4000B	8	3/8-24 x 1-1/2" Bracket Stud
2	S3402N	8	3/8" AN Washer
3	F1282	8	3/8-24 "Jet" Nut
4	B1710DD	2	Heavy Duty Dual Caliper Mounting Bracket
5	B1301E	8	3/8-24 Press Nut (installed in B1710DD)
6	B2792	1	Right Hand HD/MD directional rotor
7	B2793	1	Left Hand HD/MD directional rotor
8	B1301H	32	.025" thick caliper shim
9	B1301J	8	1/16" thick caliper washer
10	B5000Y	8	3/8-24 x 1 1/8" caliper bolt
11	*B5010	8	Soft 4-piston caliper pad
12	*B5020	8	Hard-metallic 4-piston caliper pad
13	B5002	2	Right Hand 4-Piston Caliper
14	B5004	2	Left Hand 4-Piston Caliper
15	P2316	4	1/8" NPT x -3AN Fitting (installed in B5002 & B5004)

*Kit contents will vary depending on application to be determined while ordering.

FIGURE # 1: Exploded B1711WCD Assembly View

Item#	Torque spec (ft-lbs)
3	40
9*	35

*Must apply red loctite

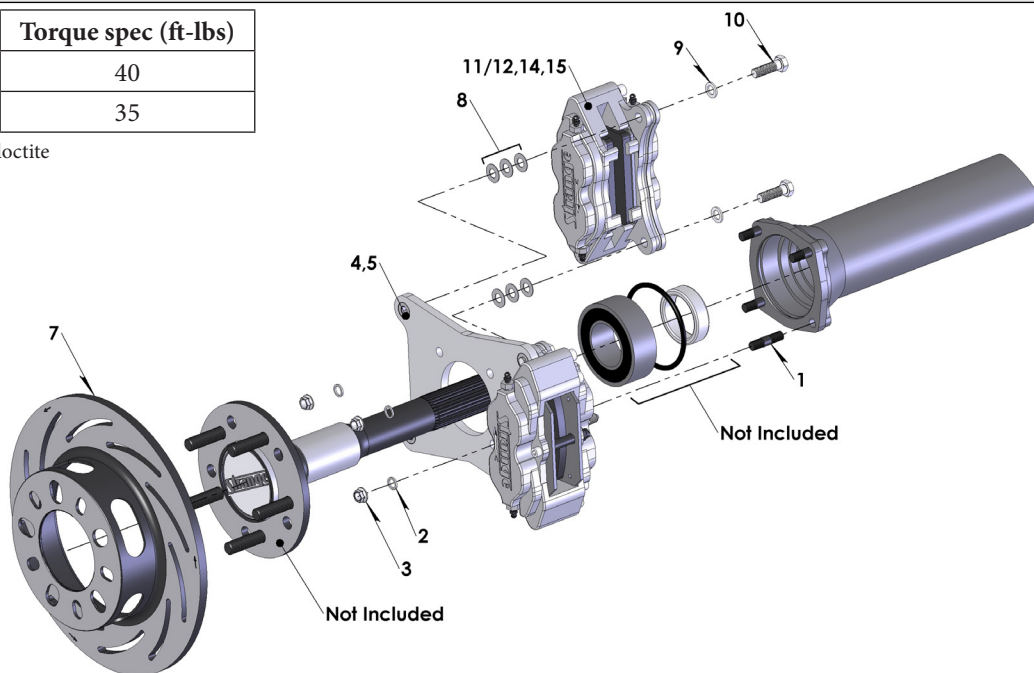

Installation instructions

1. Raise and support rear of vehicle on a level surface using suitable equipment.
2. Remove wheel, axle, and current brakes.
3. Remove bearing, and wedding ring from the axle, and caliper mount from the housing end.
4. Check the axle for any signs of twisting or run out and repair or replace as needed. The maximum allowable run out checked between centers at the face of the flange, bearing surface, and near the splines is 0.005" total indicated run out (T.I.R.).
5. Inspect the rotor (6,7) for fit on the axle flange. The rotor should slide freely over the axle flange and seat flush against the face of the axle flange. The rotor must center on the axle flange or axle studs. If the axle flange is too large, it must be machined to 6.240" diameter.
6. Inspect the housing end for straightness and repair as necessary.
7. Slide the dual caliper mounting bracket (4) onto the axle with press nuts (5) facing OUTBOARD.
8. Install a new bearing on the axle, pressing only on the inner race. Before installing, apply a small amount of oil to the I.D. of the bearing to aid in installation. Make certain that the bearing fully seats against the step on the axle.
Note: The double ball bearing (not included) can be installed facing either direction.
9. Press the wedding ring onto the axle until it seats flush against the bearing.
10. Install the 3/8-24 bracket studs (1) into the housing end and hand-tighten: Longer thread length to face OUTBOARD.
11. Carefully slide the axle into the housing until the bearing bottoms out in the housing end.
12. Engage the caliper mounting bracket (4) onto the bracket studs (1) and install using the 3/8" AN washers and 3/8-20 "jet" nuts (3). Torque "jet" nuts (3) to 40 ft-lbs.
13. Slide the rotor (6,7) over the wheel studs and axle flange, ensuring that the rotor sits flat on the face of the axle flange.
Note: Slotted rotors mount with the arrow pointing in the direction of normal rotation (See Figure 2).
- Please read B1850 instructions for complete caliper instructions if using soft pads.
- Please read B1855 instructions for complete caliper instructions if using metallic pads.
14. Attach caliper (13,14) with the arrow facing in the direction of normal rotor rotation using 3/8"-24 caliper bolts (10) with red loctite and 1/16" thick flat washers (9). Use 0.025" thick caliper shims (8) to center the caliper over the rotor, making sure pads contact the rotor evenly. The caliper bolt (10) should be fully engaged into the press nut (5). If the bolt is over engaged, use any remaining shims under the head of the bolt to prevent it from running into the rotor. Torque the caliper mounting bolts (10) to 35 ft-lbs.
15. Connect the brake lines to the calipers. Calipers are tapped to 1/8"-27 NPT and supplied with -3AN fittings. Use proper adapters to connect them to existing lines or use new -3AN braided steel line (teflon lined). Bleed the calipers with DOT 4 or DOT 5.1 brake fluid ONLY.
16. A proper break in procedure is required to avoid brake fade and uneven rotor deposits from the pads. It consists of 8-10 brake applications increasing in harshness while allowing the brakes to cool slightly in between; do not keep the brakes applied between stops. After the last stop the brakes should be allowed to cool completely.

Note: After the initial installation of this kit, ensure that there is adequate clearance between all braking and chassis components by moving the suspension all the way up and down throughout its travel. Additionally, make sure that the brake lines are not interfering with the wheel travel, or subject to binding or kinking. Operate the vehicle in a cautious manner until you determine that the brakes are functioning properly. Routinely check and re-torque all bolts.

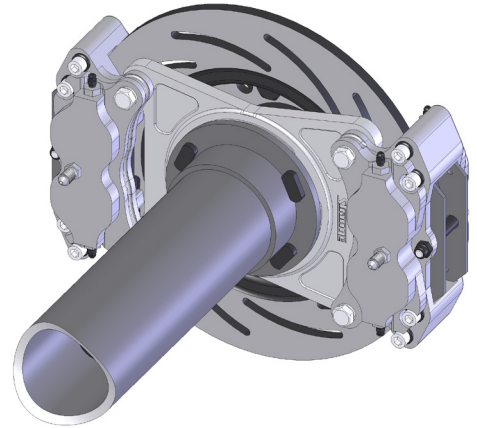
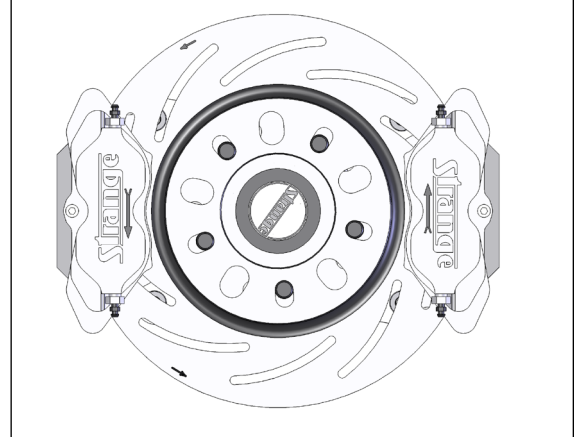

FIGURE # 2: Rotors and calipers are directional



WARNING - RACING IS HAZARDOUS · STRANGE BRAKES ARE FOR LEGAL DRAG RACING ONLY

Disclaimer of Warranty - Purchasers using Strange Engineering racing components and equipment any and all inventory services, purchasers acknowledge that due to differing conditions and circumstances under which all equipment and parts are installed and used, purchasers are not relying on Strange Engineering Co. skill or judgment to select or furnish the proper part or equipment. Purchasers expressly affirm they are relying upon their own skill or judgment to select and purchase suitable goods. Strange Engineering Co. makes no warranties whatsoever, expressed or implied, oral or written, to purchasers. There is no warranty of merchantability made to purchasers. Strange Engineering Co., further excludes any implied warranty of fitness with respect to racing and equipment, any and all inventory and service.