

# Strange

Page 1 of 2

Oct 23, 2020

## **PRO SERIES 4-PISTON FRONT BRAKE KIT INSTRUCTIONS**

**KIT #**  
B4162WC -"A" Mopar 10"  
Drum Spindles

**APPLICATIONS**  
1965-1972 Dart  
1965-1969 Barracuda

### **Before you begin installation:**

- Consult Directional Caliper Kit installation instructions to mount the brake caliper.
- Consult pg. 112 of Strange Engineering catalog for available brake lines.
- Inspect upper and lower ball joints for excessive play and replace as needed.
- Consult factory service manual to remove and disassemble axle carrier and axle hub.
- Brake rotors are shipped with an oil film on the surface to prevent rust and must be cleaned before installation.
- Clean and inspect hub for damage (spun wheel bearings, stripped threads, etc.) and repair or replace as needed.
- Read these instructions thoroughly and save for future reference.
- If after reading these installation instructions, you have any questions or comments, please do not hesitate to call us.

### **Important Notes**

- Strange Engineering brake kits are designed for drag racing only
- B5010 Semi-metallic brake pad minimal thickness is 0.200"
- B2793/B2792 Steel brake rotor minimal thickness is 0.312"
- Calipers are tapped to 1/8"-27 NPT and supplied with -3AN fittings
- B1720WC Pro Race Steel Brake Kit eliminates emergency brake

## **KIT CONTENTS**

| <b>ITEM#</b> | <b>PART#</b> | <b>QTY</b> | <b>DESCRIPTION</b>                                  |
|--------------|--------------|------------|---|
| 1            | B2792        | 1          | Heavy Duty Brake Rotor Passenger Side               |
| 2            | B4182C       | 2          | Brake Rotor Spacer                                  |
| 3            | B4182E       | 4          | M12 x 1.75 x 50mm Long Caliper Mount Bolt           |
| 4            | B4182B       | 1          | Brake Caliper Mount Passenger Side                  |
| 5            | B1301E       | 4          | 3/8-24 Press Nut (pre-installed in B4182B & B4182A) |
| 6            | B4182D       | 4          | Brake Caliper Mount Spacer                          |
| 7            | B4152F       | 4          | M12 x 1.75 Nylon Lock Nut                           |
| 8            | B1301H       | 16         | 3/8 I.D. x 0.025 Thick Caliper Shim                 |
| 9            | B5002        | 1          | Brake Caliper Passenger Side                        |
| 10           | B5010        | 4          | Semi--metallic Brake Pads                           |
| 11           | B1301J       | 4          | Caliper Bolt Washer                                 |
| 12           | B5000Y       | 4          | 3/8-24 x 1.125" Caliper Mounting Bolt               |
| 13           | B2793        | 1          | Heavy Duty Brake Rotor Driver Side                  |
| 14           | B4182A       | 1          | Brake Caliper Mount Driver Side                     |
| 15           | B5004        | 1          | Brake Caliper Driver Side                           |

A stylized, handwritten-style logo for 'Supra' in a grey color, positioned at the bottom center of the page.

Figure # 1

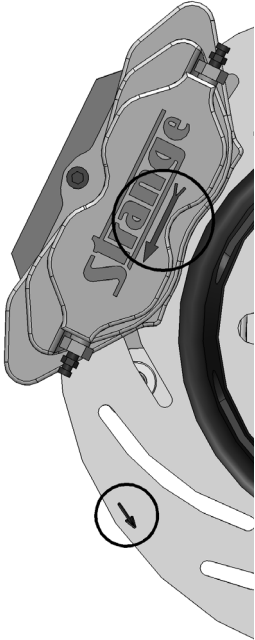

**Installation instructions**

1. Slide two caliper bracket bolts (3) through the mounting holes of the caliper bracket (4).
2. Slide two caliper bracket spacers (6) onto the caliper bracket bolts (3) to sit flush between the caliper bracket (4) and surface of Toyota caliper ears.
3. Secure caliper bracket (4) to the spindle body using the two lock nuts (7). Torque the caliper bracket bolts (3) to 50 ft-lbs.  
**Note:** Remove any rust on mounting surfaces of Toyota caliper ears using wire brush or similar tools.
4. Slide the rotor spacer (2) through the wheel studs and over the hub center.  
**Note:** Remove any rust on mounting surfaces of Toyota hub. Lug nuts can be installed to avoid damaging wheel stud threads while cleaning mounting surface.
5. Slide the rotor (1) over the wheel studs flush to the face of the rotor spacer (2).  
**Note:** Slotted rotors mount with the arrow pointing in the direction of normal rotation. (See Figure # 1)
6. Attach the caliper (9) to the caliper mounting bracket (4) using the two caliper bolts (12) with red loctite, flat washers (11) and shims (8). Torque caliper bolts (12) to 35 ft-lbs. The number of shims (8) installed will vary because not all spindles are exactly identical. Therefore, determine the proper amount of shims by positioning the caliper as closely as possible to the center of the rotor. Also, the passenger and driver side do not necessarily use the same amount of shims.  
**Note:** The arrow on the caliper must face the normal rotation of the rotor/wheel. (See Figure # 1)
7. Connect the hydraulic lines to the calipers. Calipers are tapped to 1/8"-27 NPT and supplied with -3AN fittings. Use proper adapters to connect or use new -3AN braided steel line (teflon lined). Bleed the calipers with DOT 4 or DOT 5.1 brake fluid ONLY.
8. A proper break in procedure is required to avoid brake fade and uneven rotor deposits from the pads. It consists of 8-10 brake applications increasing in harshness while allowing the brakes to cool slightly in between; do not keep the brakes applied between stops. After the last stop the brakes should be allowed to cool completely.

FIGURE # 2: Exploded B4162WC Assembly View

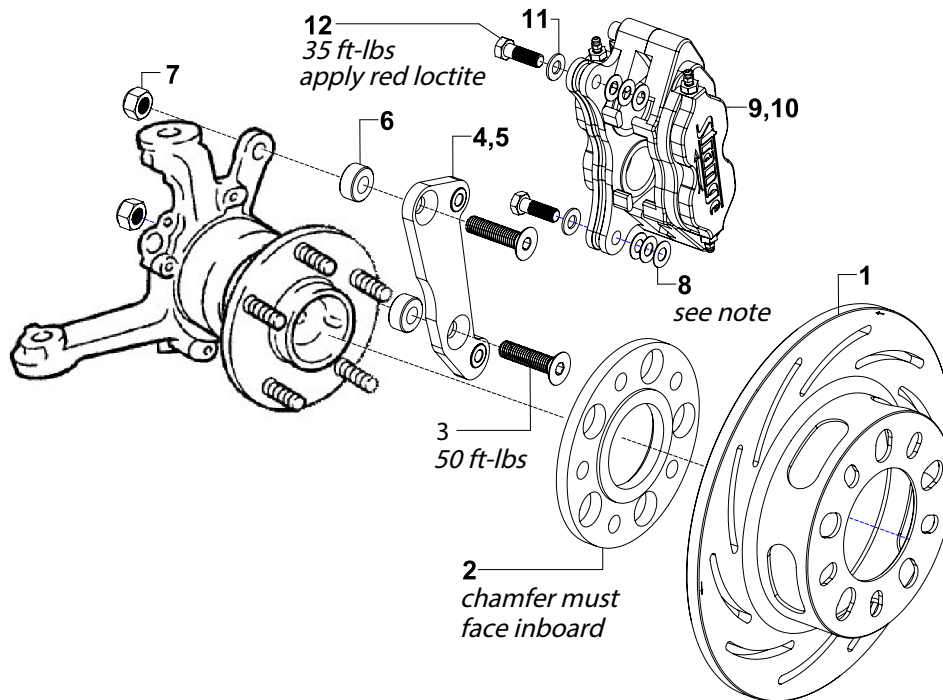

WARNING - RACING IS HAZARDOUS · STRANGE BRAKES ARE FOR LEGAL DRAG RACING ONLY

Disclaimer of Warranty - Purchasers using Strange Engineering racing components and equipment any and all inventory services, purchasers acknowledge that due to differing conditions and circumstances under which all equipment and parts are installed and used, purchasers are not relying on Strange Engineering Co. skill or judgment to select or furnish the proper part or equipment. Purchasers expressly affirm they are relying upon their own skill or judgment to select and purchase suitable goods. Strange Engineering Co. makes no warranties whatsoever, expressed or implied, oral or written, to purchasers. There is no warranty of merchantability made to purchasers. Strange Engineering Co., further excludes any implied warranty of fitness with respect to racing and equipment, any and all inventory and service.