

Strange

Page 1 of 2

Oct 21, 2020

HEAVY DUTY 4-PISTON FRONT BRAKE KIT INSTRUCTIONS

KIT #
B4172WC - '55-'57' Chevy

APPLICATIONS
'55-'77 Chevy using factory
drum brake spindles

Before you begin installation:

-Strange Engineering brake kits are designed for DRAG RACING ONLY!

-Read these instructions thoroughly and save for future reference.

-If after reading these installation instructions, you have any questions or comments, please do not hesitate to call us.

KIT CONTENTS			
ITEM#	PART#	QTY	DESCRIPTION
1a	B2795	1	Left hand rotor
1b	B2796	1	Right hand rotor
2	B4154E	2	Hub cap
3	S3520F	2	O-ring
4	B4170B	2	1/8" Front wheel spacer
5	B1324E	2	Outer hub bearing cone (LM11949)
6	B1324D	2	Outer bearing cup (LM11910)
7	B4154C	2	Front "H" Hub
8	B1320H	2	Inner bearing cup (LM67010)
9	B1320J	2	Inner bearing cone (LM67048)
10	B1344D	2	Seal C/R #18558
11	A1028B	10	1/2" Stripper Washer
12	A1028A	10	1/2-20 x 2-1/2" Taper head SHCS
13	B1346B	2	7/16-20 x 2-1/2" HHCS
14a	B1388AL	1	Left hand Caliper bracket
14b	B1388AR	1	Right hand Caliper bracket
15	B1301E	4	3/8-24 Press nut
16	B4172A	2	5/8-18 x 1.75" FHS
17	B1301H	16	3/8 ID x 0.025 Shim
18	B1747A	2	5/8 ID x 13/16 Long stand
19	B1380B	10	5/8 ID x 0.025 Shim
20a	B5002	1	Left hand Caliper
20b	B5004	1	Right hand Caliper
21	B5010	4	Soft Strange 4-Piston caliper pad
22	P2316	2	-1/8NPT x #3AN fitting
23	B1301J	4	3/8 ID 1/16" thick flat washer
24	B5000Y	4	3/8-24 x 1.125 HHCS
25	B1346C	2	7/16-20 Locknut
26	P2316C	2	Plastic cap for #3AN fitting

WARNING - RACING IS HAZARDOUS - STRANGE BRAKES ARE FOR LEGAL DRAG RACING ONLY

Disclaimer of Warranty - Purchasers using Strange Engineering racing components and equipment any and all inventory services, purchasers acknowledge that due to differing conditions and circumstances under which all equipment and parts are installed and used, purchasers are not relying on Strange Engineering Co. skill or judgment to select or furnish the proper part or equipment. Purchasers expressly affirm they are relying upon their own skill or judgment to select and purchase suitable goods.

Strange Engineering Co. makes no warranties whatsoever, expressed or implied, oral or written, to purchasers. There is no warranty of merchantability made to purchasers. Strange Engineering Co., further excludes any implied warranty of fitness with respect to racing and equipment, any and all inventory and service.

Installation instructions

Figure # 1

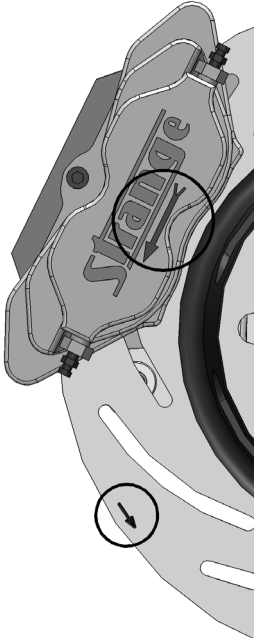

1. Raise and support front of vehicle on a level surface using suitable equipment.
2. Remove wheel, and stock disk brake components. Inspect all ball joints for excessive play and replace as needed.
3. Install 1/2" Dia. wheel studs (12) in front hub (7) using 1/2" I.D. wheel stud washer (11) and a small amount of BLUE Loc-tite®. Torque all studs to 65 ft-lbs.
4. Install the caliper mounting bracket (14). Mount using the 7/16"-20 HHCS bolts (13) and lock nut (25) as well as 5/8-18 x 1.75" FHS bolt (16).
5. **Note:** A bearing packer is recommended for this procedure; If one is not available work as much grease as possible into the cage and around the rollers.
6. Wipe a thin layer of wheel bearing grease on the bearing surface of the inner and outer cups (6, 8) and then place inner bearing cone (9) into the front hub (7).
7. Press the hub seal (10) into the inboard side of the hub (7) flush to the outer face of the hub (7).
8. Slide the hub assembly onto the spindle, then slide the outer bearing cone (5) into the hub (7).
9. Install the stock key washer and the spindle castle nut.
10. Mount the wheel and tire assembly on the hub and snug the lug nuts.
11. While rotating the wheel, torque the spindle nut to approximately 20 ft-lbs.
12. Loosen the spindle nut until the wheel spins freely and there is no end play.
13. Install the cotter pin, aluminum hub cap (2), and remove the wheel and tire.
14. Slide the rotor (1) over the wheel studs flush to the face of the hub (7).

Note: Slotted rotors mount with the arrow pointing in the direction of normal rotation (See Figure #1).

- Please read B1850 instructions for complete caliper instructions.

15. Attach caliper (20) with the arrow facing in the direction of normal rotor rotation using 3/8"-24 caliper bolts (24) with red loctite and 3/8" I.D. washers (23). Use 3/8" I.D. caliper shims (17) to center the caliper over the rotor, contact the rotor evenly. The caliper bolt (23) should be fully engaged into the press nut. If the bolt is over engaged, use any remaining shims under the head of the bolt to prevent it from running into the rotor. Torque the caliper mounting bolts (24) to 35 ft-lbs.
16. Connect the hydraulic lines to the calipers. Calipers are tapped to 1/8"-27 NPT and supplied with -3AN fittings. Use proper adapters to connect them to existing lines or use new -3AN braided steel line (teflon lined). Bleed the calipers with DOT 4 or DOT 5.1 brake fluid ONLY. Mount the tire and wheel.

Notes: A proper break in procedure is required to avoid brake fade and uneven rotor deposits from the pads. It consists of 8-10 brake applications increasing in harshness while allowing the brakes to cool slightly in between; do not keep the brakes applied between stops. After the last stop the brakes should be allowed to cool completely. Operate the vehicle in a cautious manner until you determine that the brakes are functioning properly. Routinely check and re-torque all bolts.

FIGURE # 2: Exploded B4172WC Assembly View

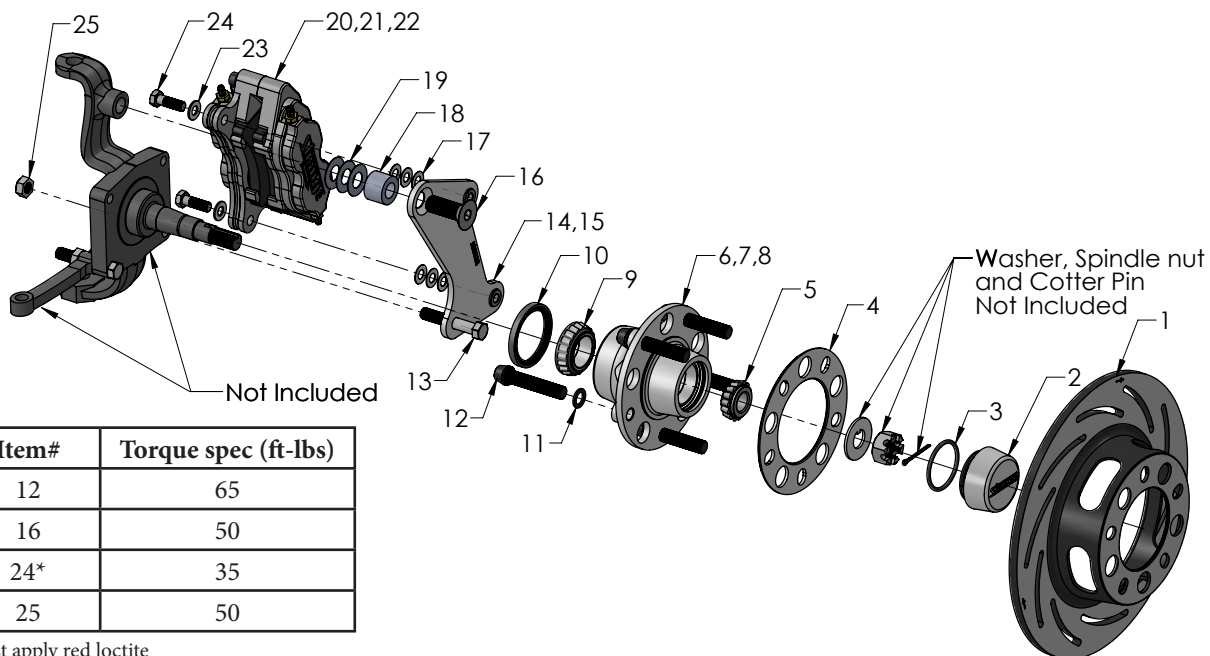

Item#	Torque spec (ft-lbs)
12	65
16	50
24*	35
25	50

*Must apply red loctite