

Strange

PRO SERIES 4-PISTON FRONT BRAKE KIT INSTRUCTIONS	KIT #	APPLICATIONS
	B4166WC	1963 - 64 Corvette
	B4168WC	1965 - 68 Corvette
	B4170WC	1969 - 82 Corvette

Before you begin installation:

Corvette spindles vary from 1963-1982, **we recommend that you send in your spindles** to address variations. The changes will be covered in the price of the brake kit.

Read these instructions thoroughly and save for future reference.

If after reading these installation instructions, you have any questions or comments, please do not hesitate to call us.

See pg. 3 for spacer, bolt and spindle hole information

Important Notes

- Strange Engineering brake kits are designed for drag racing only
- B5010 Semi-metallic brake pad minimal thickness is 0.200"
- B2795/B2796 Steel brake rotor minimal thickness is 0.312"
- Calipers are tapped to 1/8"-27 NPT and supplied with -3AN fittings

KIT CONTENTS			
ITEM#	PART#	QTY	DESCRIPTION
1a	B2795	1	Tapered rotor RH
1b	B2796	1	Tapered rotor LH
2	B4170B	2	1/8" Thick front wheel spacer
3	B4154E	2	Hub Cap
4	S3520F	2	#222 Buna O-ring
6a	B1757C	2	Timken LM12748F (B4170WC)
6b	B1324E	2	Timken LM11949 (B4166WC/B4168WC)
6a	B1330C	2	Timken LM12710 (B4170WC)
6b	B1324D	2	Timken LM11910 (B4166WC/B4168WC)
7a	B4154C	2	Front Hub "H" 4.75 B.C (B4170WC)
7b	B1324A	2	Front hub "F" (B4166WC/B4168WC)
8	A1028A	10	1/2-20 x 2.5" Taper head SHCS
9	A1028B	10	1/2" Stripper Washer
10a	B1330A	2	Timken L68110 (B4170WC)
10b	B1320H	2	Timken LM67010 (B4166WC/B4168WC)
11a	B1330B	2	Timken L68149 (B4170WC)
11b	B1320J	2	Timken LM67048 (B4166WC/B4168WC)
12a	B1729A	2	Seal C/R 19728 (B4170WC)
12b	B1344D	2	Seal C/R #18558 (B4166WC/B4168WC)
13a	B1388AL	1	Caliper mount 63-68 Corvette left hand
13b	B1388AR	1	Caliper mount 63-68 Corvette right hand
14	B1301E	4	3/8-24 Press nut
15a	B4170A	2	5/8 ID X 1.625" Long stand (varies, see page 3)
15b	B1344B	2	5/8 ID X 1-1/8" Long stand
16	B1301H	16	3/8 ID x 0.025 thick shim
17	B5010	4	Soft pad
18	B5002	1	Caliper RH
19	B5004	1	Caliper LH
20	P2316	2	Fitting -1/8 NPT
21	P2316C	2	Plastic cap
22	B1301J	4	Washer -3/8 ID 1/16 thick flat
23	B5000Y	4	3/8-24 X 1.125" HHCS
-	B1380B	10	5/8 ID X 0.25 Shim

Installation instructions

Figure # 1

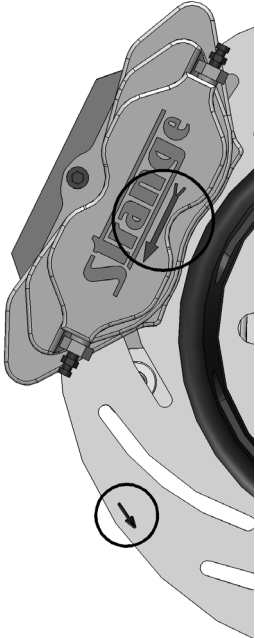

1. Raise and support front of vehicle on a level surface using suitable equipment.
2. Remove wheel, and stock disk brake components. Inspect all ball joints for excessive play and replace as needed.
3. Install 1/2" Dia. wheel studs (8) in front hub (7) using 1/2" I.D. wheel stud washer (9) and a small amount of BLUE Loc-tite®. Torque all studs to 65 ft-lbs.
4. Install the caliper mounting bracket (13). Mount using the HHCS bolts and lock nut as well as FHS bolt.
5. Wipe a thin layer of wheel bearing grease on the bearing surface of the inner and outer cups (6, 8) and then place inner bearing cone (11) into the front hub (7).
6. Press the hub seal (10) into the inboard side of the hub (7) flush to the outer face of the hub (7).
7. Slide the hub assembly onto the spindle, then slide the outer bearing cone (5) into the hub (7).
8. Install the stock key washer and the spindle castle nut.
9. Mount the wheel and tire assembly on the hub and snug the lug nuts.
10. While rotating the wheel, torque the spindle nut to approximately 20 ft-lbs.
11. Loosen the spindle nut until the wheel spins freely and there is no end play.
12. Install the cotter pin, aluminum hub cap (3), and remove the wheel and tire.
13. Slide the rotor (1) over the wheel studs flush to the face of the hub (7).

Note: Slotted rotors mount with the arrow pointing in the direction of normal rotation (See Figure #1).
- Please read B1850 instructions for complete caliper instructions.

14. Attach caliper (18) with the arrow facing in the direction of normal rotor rotation using 3/8"-24 caliper bolts (23) with red loctite and 3/8" I.D. washers (22). Use 3/8" I.D. caliper shims (16) to center the caliper over the rotor, making sure pads contact the rotor evenly. The caliper bolt (23) should be fully engaged into the press nut. If the bolt is over engaged, use any remaining shims under the head of the bolt to prevent it from running into the rotor. Torque the caliper mounting bolts (23) to 35 ft-lbs.

15. Connect the hydraulic lines to the calipers. Calipers are tapped to 1/8"-27 NPT and supplied with -3AN fittings. Use proper adapters to connect them to existing lines or use new -3AN braided steel line (teflon lined). Bleed the calipers with DOT 4 or DOT 5.1 brake fluid ONLY . Mount the tire and wheel.

Notes: A proper break in procedure is required to avoid brake fade and uneven rotor deposits from the pads. It consists of 8-10 brake applications increasing in harshness while allowing the brakes to cool slightly in between; do not keep the brakes applied between stops. After the last stop the brakes should be allowed to cool completely. Operate the vehicle in a cautious manner until you determine that the brakes are functioning properly. Routinely check and re-torque all bolts.

FIGURE # 2: Exploded B4107WC Assembly View

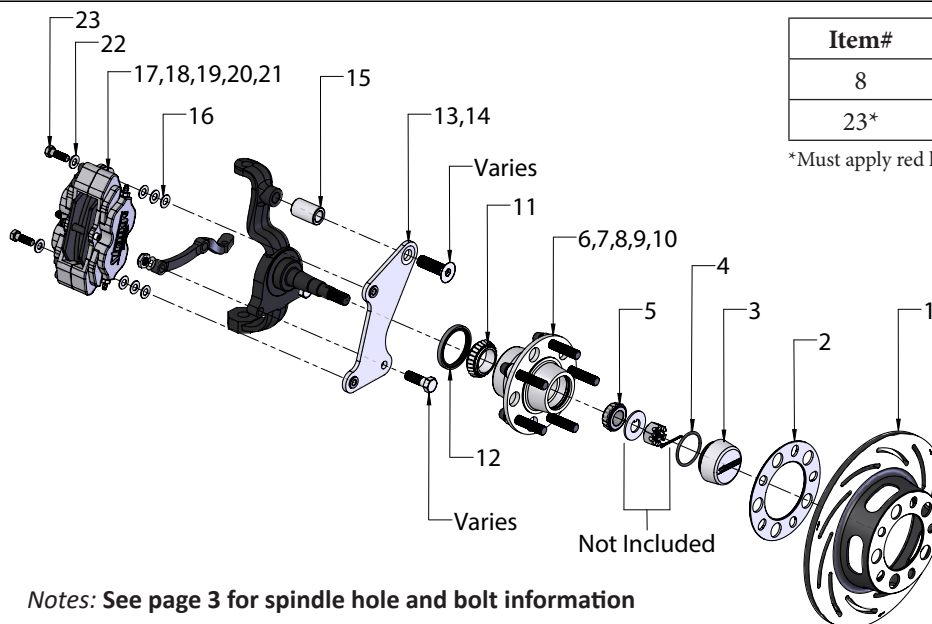

*Must apply red loctite

Notes: See page 3 for spindle hole and bolt information

Mounting hole modifications & Bolt length

CALIPER BRACKET UPPER MOUNTING HOLE

- Some spindles have a 5/8-18 tapped hole, others have an 11/16-18 tapped hole
- If the spindle has the 5/8-18 thread no modifications are necessary
- If the spindle has the 11/16-18 thread a 5/8-18 helicoil must be installed

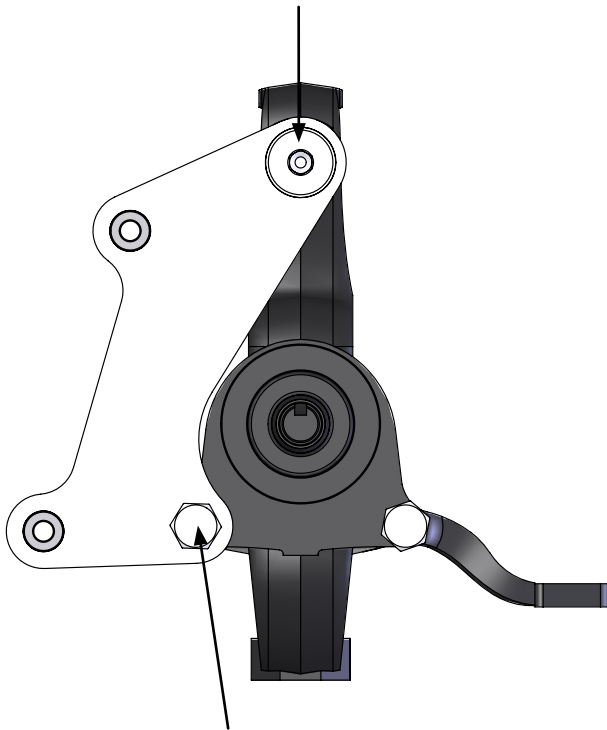

CALIPER BRACKET LOWER MOUNTING HOLE

- Some spindles are drilled for a 7/16" bolt and others for a 1/2" bolt
- Our caliper brackets have a 7/16" hole
- If the spindle has a 7/16" hole, no modification is necessary
- If the spindle has a 1/2" hole then the caliper mount needs to be opened up to 1/2"

CALIPER BRACKET UPPER MOUNTING HOLE BOLT LENGTH

- Depending on what spacer height is required, the appropriate length bolt must be chosen

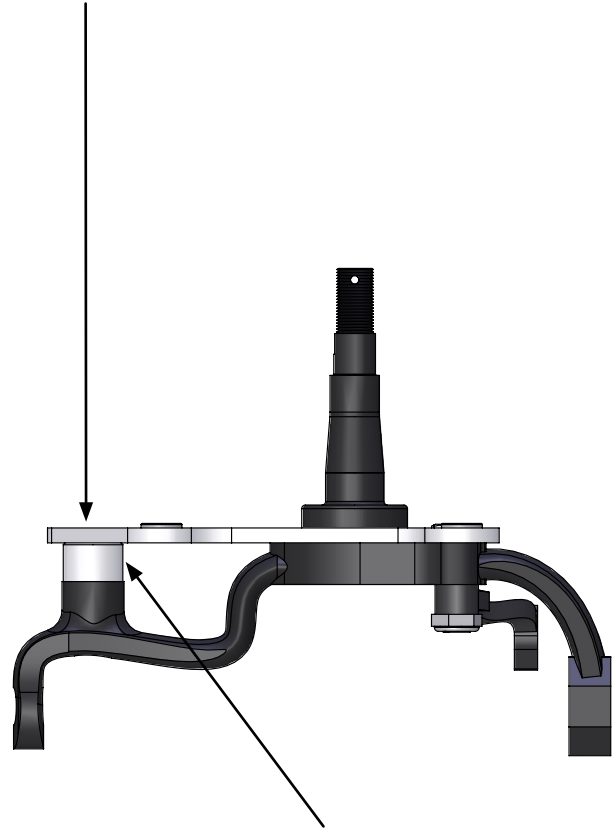

CALIPER BRACKET UPPER MOUNTING HOLE SPACER

- Spacer heights vary
 - Custom spacers will have to be made if one of our standard sizes doesn't fit
- | | | |
|-----------------|---|-------------------|
| '63 - '64 Vette | - | 1-1/8 Long spacer |
| '65 - '68 Vette | - | 1-13/16 Long |

WARNING - RACING IS HAZARDOUS · STRANGE BRAKES ARE FOR LEGAL DRAG RACING ONLY

Disclaimer of Warranty – Purchasers using Strange Engineering racing components and equipment any and all inventory services, purchasers acknowledge that due to differing conditions and circumstances under which all equipment and parts are installed and used, purchasers are not relying on Strange Engineering Co. skill or judgment to select or furnish the proper part or equipment. Purchasers expressly affirm they are relying upon their own skill or judgment to select and purchase suitable goods.

Strange Engineering Co. makes no warranties whatsoever, expressed or implied, oral or written, to purchasers. There is no warranty of merchantability made to purchasers. Strange Engineering Co., further excludes any implied warranty of fitness with respect to racing and equipment, any and all inventory and service.