

Strange

Page 1 of 2

Oct 21, 2020

PRO SERIES 4-PISTON FRONT BRAKE KIT INSTRUCTIONS

KIT #
B4162WC -"A" Mopar 10"
Drum Spindles

APPLICATIONS
1965-1972 Dart
1965-1969 Barracuda

Before you begin installation:

- Strange Engineering brake kits are designed for DRAG RACING ONLY!
- Read these instructions thoroughly and save for future reference.
- If after reading these installation instructions, you have any questions or comments, please do not hesitate to call us.

KIT CONTENTS

ITEM#	PART#	QTY	DESCRIPTION
1	A1028A	10	1/2"-20 x 2.5" Wheel stud
2	A1028B	10	1/2" I.D. Wheel stud washer
3	B1301E	4	3/8"-24 Press nut (Installed in B4162AL & B4162AR)
4	B1320H	2	Inner hub bearing cup (Timken LM67010 installed in B4154SP)
5	B1320J	2	Inner hub bearing cone (Timken LM67048)
6	B4154SP	2	Front Hub "HS" 4.5" B.C.
7	B1324D	2	Outer hub bearing cup (Timken LM11910 installed in B4154SP)
8	B1324E	2	Outer hub bearing cone (Timken LM11949)
9	B2795	1	Right hand HD/MD tapered rotor
10	B2796	1	Left hand HD/MD tapered rotor
11	B1301H	16	3/8" I.D. x 0.025" Thick caliper shim
12	B1301J	4	3/8" I.D. x 1/16" Thick flat washer
13	B5000Y	4	3/8"-24 x 1.125" Caliper bolt
14	B5010	4	Soft Metallic 4-piston caliper pad
15	B5002	1	Right hand 4-piston caliper
16	B5004	1	Left hand 4-piston caliper
17	P2316	2	1/8" NPT x -3AN Fitting (installed in B5002 & B5004)
18	B4154E	2	Aluminum hub cap
19	B4162AR	1	R.H Caliper Bracket
20	B4162AL	1	L.H. Caliper Bracket
21	S3520F	2	#222 Buna O-ring (Installed on B4154E)
22	A1026A	2	1/2"-20 x 3" HHCS GR8
23	H1135C	2	1/2"-20 Flexlok Nut
24	B1386C	2	7/16"-20 x 2" HHCS GR8
25	B1346C	2	7/16"-20 Locknut
26	B1320N	2	Hub Seal (National #40494S)

WARNING - RACING IS HAZARDOUS · STRANGE BRAKES ARE FOR LEGAL DRAG RACING ONLY

Disclaimer of Warranty - Purchasers using Strange Engineering racing components and equipment any and all inventory services, purchasers acknowledge that due to differing conditions and circumstances under which all equipment and parts are installed and used, purchasers are not relying on Strange Engineering Co. skill or judgment to select or furnish the proper part or equipment. Purchasers expressly affirm they are relying upon their own skill or judgment to select and purchase suitable goods. Strange Engineering Co. makes no warranties whatsoever, expressed or implied, oral or written, to purchasers. There is no warranty of merchantability made to purchasers. Strange Engineering Co., further excludes any implied warranty of fitness with respect to racing and equipment, any and all inventory and service.

Installation instructions

Figure # 1

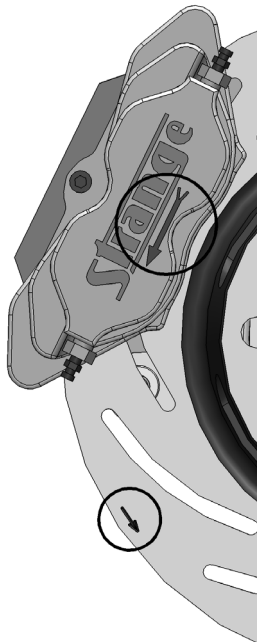

1. Raise and support front of vehicle on a level surface using suitable equipment.
2. Remove wheel, and stock drum brake components. Inspect all ball joints for excessive play and replace as needed.
3. Install 1/2" Dia. wheel studs (1) in front hub (6) using 1/2" I.D. wheel stud washer (2) and a small amount of BLUE Loc-tite®. Torque all studs to 65 ft-lbs.
Note: Consult your wheel and/or lug nut manufacturer for proper lug nut torque.
4. Install the caliper mounting bracket (19,20) using the 7/16"-20 hex bolt (24) in the top spindle hole along with the 7/6"-20 locknut (25), and the 1/2"-20 hex bolt (22) along with the 1/2"-20 flexlok nut (23) in the bottom spindle hole. Torque to 45 ft-lbs and 55 ft-lbs respectively.
Note: Ensure that the press nuts (3) installed in the caliper bracket face OUTBOARD.
5. Pack inner (5) and outer bearing cones (8) with NLGI 1 wheel bearing grease.
Note: A bearing packer is recommended for this procedure; If one is not available work as much grease as possible into the cage and around the rollers.
6. Wipe a thin layer of wheel bearing grease on the bearing surface of the inner and outer cups (4, 7) and then place inner bearing cone (5) into the front hub (6).
7. Press the hub seal (26) into the inboard side of the hub (6) flush to the outer face of the hub (6).
8. Slide the hub assembly onto the spindle, then slide the outer bearing cone (8) into the hub (6).
9. Install the stock key washer and the spindle castle nut.
10. Mount the wheel and tire assembly on the hub and snug the lug nuts.
11. While rotating the wheel, torque the spindle nut to approximately 20 ft-lbs.
12. Loosen the spindle nut until the wheel spins freely and there is no end play.
13. Install the cotter pin, aluminum hub cap (18), and remove the wheel and tire. Note: cotter pin hole in spindle may need to be re-drilled.
14. Slide the rotor (9, 10) over the wheel studs flush to the face of the hub (6).
Note: Slotted rotors mount with the arrow pointing in the direction of normal rotation (See Figure #2).
- Please read B1850 instructions for complete caliper instructions.
15. Attach caliper (15, 16) with the arrow facing in the direction of normal rotor rotation using 3/8"-24 caliper bolts (13) with red loctite and 3/8" I.D. washers (12). Use 3/8" I.D. caliper shims (11) to center the caliper over the rotor, making sure pads contact the rotor evenly. The caliper bolt (13) should be fully engaged into the press nut. If the bolt is over engaged, use any remaining shims under the head of the bolt to prevent it from running into the rotor. Torque the caliper mounting bolts (13) to 35 ft-lbs.
Note: Because all spindles vary slightly you may not need the same amount of shim on both sides of the vehicle.
16. Connect the brake lines to the calipers. Calipers are tapped to 1/8"-27 NPT and supplied with -3AN fittings (17). Use proper adapters to connect them to existing lines or use new -3AN braided steel line (teflon lined). Bleed the calipers with DOT 4 or DOT 5.1 brake fluid ONLY.
17. A proper break in procedure is required to avoid brake fade and uneven rotor deposits from the pads. It consists of 8-10 brake applications increasing in harshness while allowing the brakes to cool slightly in between; do not keep the brakes applied between stops. After the last stop the brakes should be allowed to cool completely.
Note: After the initial installation of this kit, ensure that there is adequate clearance between all braking and chassis components by turning the wheels all the way left to right and moving them all the way up and down throughout the length of the wheel (suspension) travel. Additionally, make sure that the brake lines are not interfering with the wheel travel, or subject to binding or kinking. Operate the vehicle in a cautious manner until you determine that the brakes are functioning properly. Routinely check and re-torque all bolts.

FIGURE # 2: Exploded B4162WC Assembly View

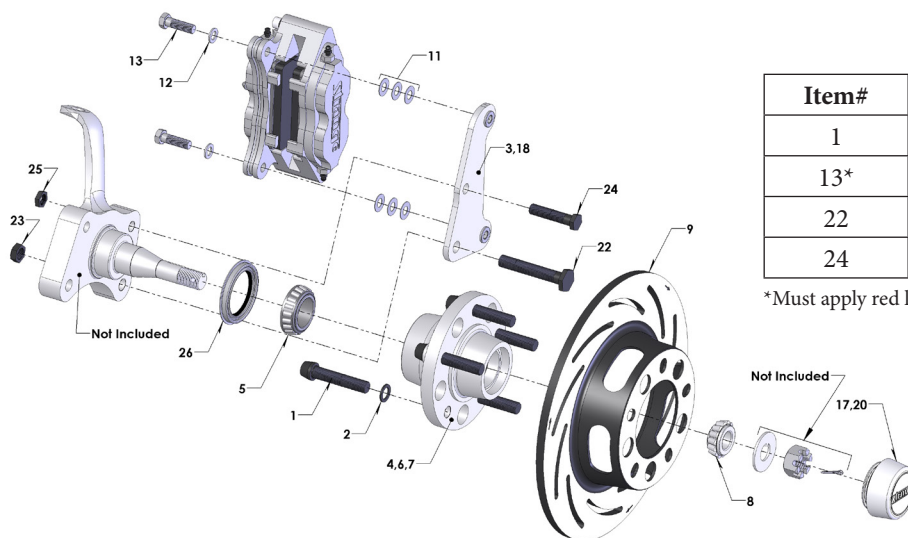

Item#	Torque spec (ft-lbs)
1	65
13*	35
22	65
24	45

*Must apply red loctite