

Strange

Page 1 of 2

Apr 29, 2020

PRO SERIES SINGLE-PISTON FRONT BRAKE KIT INSTRUCTIONS

KIT #
B4600WC - Lightweight single piston front brake kit

APPLICATIONS
Ultra struts with "Anglia" style spindles

Before you begin installation:

- Strange Engineering brake kits are designed for DRAG RACING ONLY!
- Read these instructions thoroughly and save for future reference.
- If after reading these installation instructions, you have any questions or comments, please do not hesitate to call us.

B1816 KIT CONTENTS

ITEM#	PART#	QTY	DESCRIPTION
1	B1260E	2	1/4" Stripper Washer
2	B1260I	4	3/8"-16x3" bolt
3	B1260J	2	Bridge Bolt Tube
4	B1250K	2	1/4"-20x3" bridge bolt
5	S3402N	8	3/8" AN Washer
6	B5000T	2	.125" Square O-Ring
7	L4000O	2	1/8" NPT Socket Plug
8	P2316	2	1/8" NPT x #3 AN fitting
9	P2365F	2	1/8" NPT Bleeder Assembly
10	B1260AC	2	Single Piston Caliper (outboard half)
11	B1260BC	2	Single Piston Caliper (inboard half)
12	B5000S1	2	Caliper Piston
13	B1250H	4	Garlock 08-DU06 Bearing (installed in B1260DC)
14	B1260K	4	Garlock 05-DU06 Bearing (installed in B1260CC)
15	B3311C	4	Slide Pin
16	F1282	4	3/8"-24 Jet Nut
17	B1260CC	2	"Hotdog" Bracket (inboard)
18	B1260DC	2	"Hotdog" Bracket (outboard)
19	B2510	4	Soft-Metallic brake pads

B4600WC KIT CONTENTS

ITEM#	PART#	QTY	DESCRIPTION
20	B4599AL	2	Ultra Strut Left Caliper Mount
21	B4599AR	2	Ultra Strut Right Caliper Mount
22	B2782	1	10"x1" Rotor (Right-hand)
23	B2783	1	10"x1" Rotor (Left-hand)
24	B1260	2	Single-Piston Caliper
25	F1282	4	3/8"-24 Jet Nut
26	S3402N	4	3/8" AN Washer
27	S3600T	4	3/8"-24x1" caliper bracket bolt

WARNING - RACING IS HAZARDOUS · STRANGE BRAKES ARE FOR LEGAL DRAG RACING ONLY

Disclaimer of Warranty - Purchasers using Strange Engineering racing components and equipment any and all inventory services, purchasers acknowledge that due to differing conditions and circumstances under which all equipment and parts are installed and used, purchasers are not relying on Strange Engineering Co. skill or judgment to select or furnish the proper part or equipment. Purchasers expressly affirm they are relying upon their own skill or judgment to select and purchase suitable goods.

Strange Engineering Co. makes no warranties whatsoever, expressed or implied, oral or written, to purchasers. There is no warranty of merchantability made to purchasers. Strange Engineering Co., further excludes any implied warranty of fitness with respect to racing and equipment, any and all inventory and service.

Installation instructions

1. Mount the rotor on the wheel using 3/8” studs and nuts supplied with the wheel. Torque to approximately 35 ft-lbs.
 2. Disassemble caliper by removing 3/8” caliper bolts (2) and the caliper bridge bolt (4). The slide pins (15) should remain attached to the bracket.
 3. Attach the caliper mounting bracket (20,21) to the strut body using 3/8”-24 bolts (27), 3/8” washer (26) and jet nut (25) . Torque to 35 ft-lbs.
 4. Follow the Ultra Strut instructions to assemble the wheel onto the strut body.
 5. The caliper now must be assembled onto the bracket. Using Figure 2 to assist you in making sure it is properly assembled. Install the inboard half of the caliper (11) along with the “hotdog” bracket (17) onto the slide pin (15). Insert one brake pad (19), and also insert the caliper bridge bolt (4), washer (1), and tube (3).
 6. Slide the outboard “hotdog bracket” (18) over the slide pins.
 7. Feed the outboard half of the caliper (10) either through the outside of the wheel or over the rotor.
 8. Line up the outboard caliper half and brake pad and loosely secure with the caliper bridge bolt.
 9. Re-install the 3/8” caliper bolts (2), making sure to use a washer (5) under the heads of the bolts. Torque 3/8” bolts to 30 ft-lbs and bridge bolt to 8-10 ft-lbs.
 10. Connect the hydraulic lines to the calipers. Calipers are tapped to 1/8”-27 NPT and supplied with -3AN fittings. Use proper adapters to connect them to existing lines or use new -3AN braided steel line (Teflon lines). Bleed calipers with DOT 4 or DOT 5.1 brake fluid ONLY.
 11. A proper break in procedure is required to avoid brake fade and uneven rotor deposits from the pads. It consists of 8-10 brake applications increasing in harshness while allowing the brakes to cool slightly in between; do not keep the brakes applied between stops. After the last stop the brakes should be allowed to cool completely.
- Note:** After the initial installation of this kit, ensure that there is adequate clearance between all braking and chassis components by turning the wheels all the way left to right and moving them all the way up and down throughout the length of the wheel (suspension) travel. Additionally, make sure that the brake lines are not interfering with the wheel travel, or subject to binding or kinking. Operate the vehicle in a cautious manner until you determine that the brakes are functioning properly. Routinely check and re-torque all bolts.

FIGURE # 1: Exploded B4600WC Assembly View

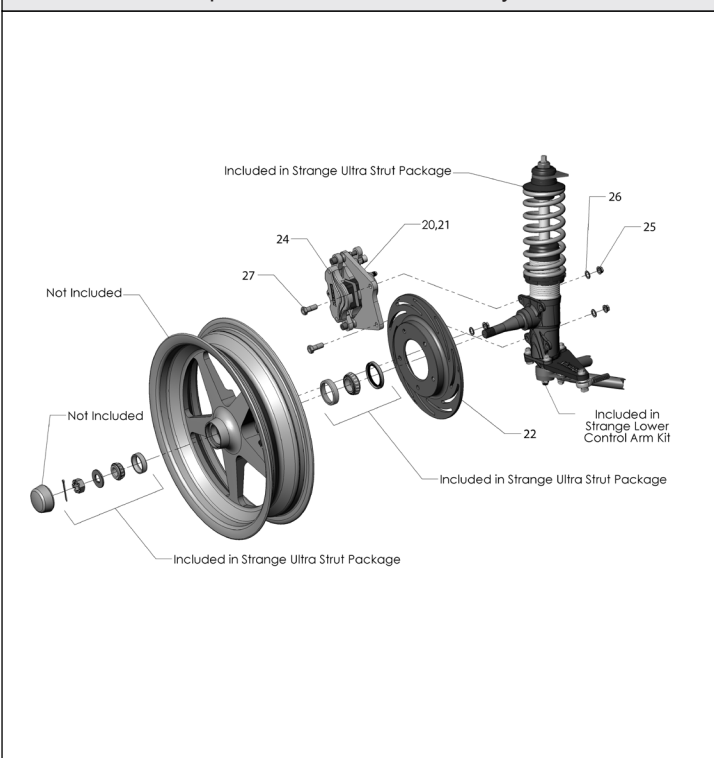

FIGURE # 2: Strange Lightweight Single Piston Components

