

Mustang Single Adjustable Steel Body Struts & Shocks

Installation to be performed by a qualified technician.

RaceStrange

- 11 Performance Settings
- Wide dampening range
- Ideal for street/strip applications
- Steel construction
- Easily accessible external knob for adjusting extension dampening
- Struts are compatible with S6001 coil-over kit (except 2005 & up)
- Fine-tune suspension geometry with Strange Caster Camber Kits (see pg. 3)

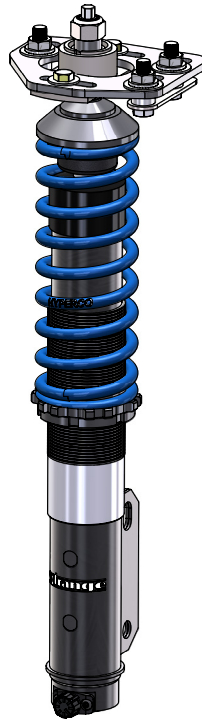
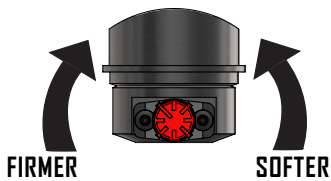

IMPORTANTNOTES

- Strange Coil-over kits and caster camber kits must be used in conjunction with one another
- Reuse factory compression bumper with all kits
- Top strut mount nuts are only provided with the purchase of caster camber kits
- Strange caster camber plates are necessary for adjusting suspension alignment if using springs that alter the vehicle's ride height
- A wheel alignment is required after the installation of these components
See alignment notes on page 7
- S6001 Coil-over kit sleeve inside diameter is 2.220
- Struts can be stroked by hand to begin proper circulation of the oil
After initial strokes the shock may feel firmer

EXTENSIONADJUSTMENT

- Knob is located at the bottom of the strut/shock
- All struts/shocks are shipped at the softest setting or position 1
- 11 Performance settings (wide range)
- Full counter-clockwise is position 1
- Full clockwise is position 11
- Each position is 1/8 of a turn
- Adjusting the extension dampening slightly affects compression
- Compression dampening can not be adjusted independently
- 3/4" 12-point socket can be used to turn the adjustment knob
- Strange Engineering struts and shocks are designed for a variety of unique vehicles and drivers. The dampening adjustments listed are starting points to begin fine tuning
- The extension adjustment information above applies to both struts and shocks

FRONT STRUTS

Part #	Year
S6001EM	87-93
S6005LM	94-2004
S6009LM	05-2010
S6011LM	2011-2014

Note: S6001EM fits only V8 models

REAR SHOCKS

Part #	Year
S6000EM	79-93
S6004LM	94-2004
S6008LM	2005-2014

Note: S6004LM does not fit Cobra with independent rear
S6000EM & S6004LM do not come with the dust shields installed. They can be pushed on when needed.
S6008LM does not fit 2013 & 2014 GT500 with track package

CASTER CAMBER KITS

Part #	Year
S6002CC79	79-89
S6002CC90	90-93
S6002CC94	94-2004

Note: A coil-over kit and caster camber kit is not available for 2005 + single adjustable struts

ADDITIONAL PARTS

Part #	Description
S6001	Coil-over kit
S1413	Spanner Wrench

Note: Hypercoil & Knight springs are available in a variety of rates and lengths

FRONT DAMPENING ADJUSTMENT

Application	Knob Position
Drag Race	2 or 3
Street	4 or 5
Road Race	7 or 8

REAR DAMPENING ADJUSTMENT

Application	Knob Position
Drag Race	5
Street	4 or 5
Road Race	7 or 8

Mustang Single Adjustable Steel Body Struts & Shocks

Caster Camber Kits

- Teflon lined bearing
- Tig welded construction
- Stainless steel bushings/spacers
- Durable & clean zinc plating finish
- Steel plates

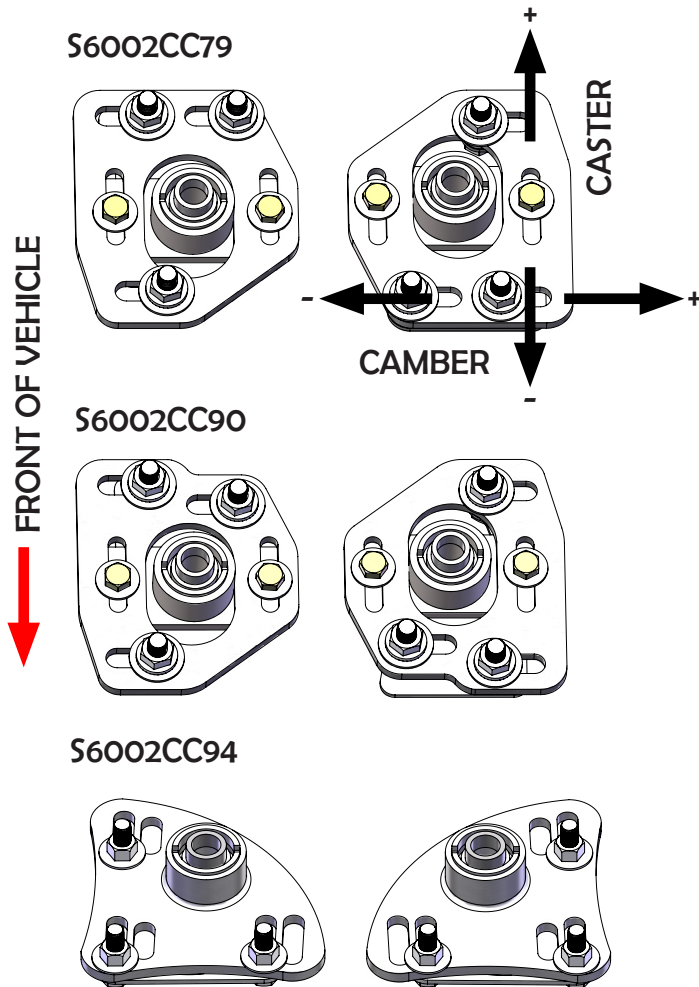

Stroke Lengths

- A Compressed Length
- B Extended Length

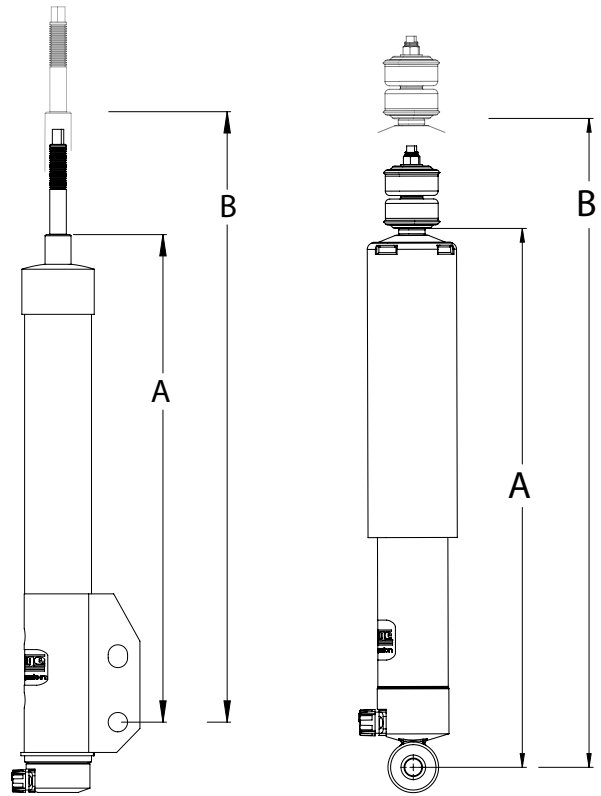

FRONT STRUTS		
Part #	A	B
S6001EM	13.0"	19.3"
S6005LM	14.4"	20.7"
S6009LM	15.8"	22.2"
S6011LM	15.8"	22.2"

REAR SHOCKS		
Part #	A	B
S6000EM	12.5"	20.0"
S6004LM	14.25"	20.25"
S6008LM	13"	20"

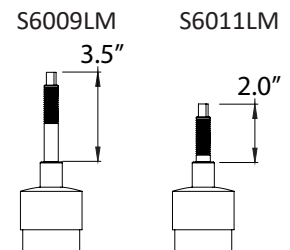

! The teflon lined bearings do NOT need to be lubricated

ADDITIONAL NOTES

A S6001EM strut and S6000EM shock can be used on 94-2004 applications if the ride height has been lowered. Referring to the stroke lengths listed, early struts and shocks have lower compression and extension lengths however, total stroke remains about the same.

Note: 2005-10 & 2011+ have different rod shoulder to rod end lengths as shown

Mustang Single Adjustable Steel Body Struts & Shocks

S6001EM & S6005LM Strut with Factory Strut Mount

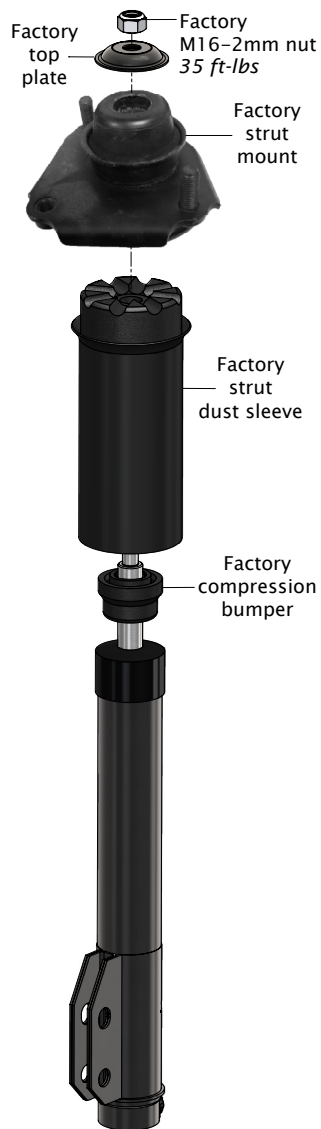

Notes:

Reuse or replace top mount nuts
Reuse all factory components shown

S6009LM & S6011LM Strut with Factory Strut Mount

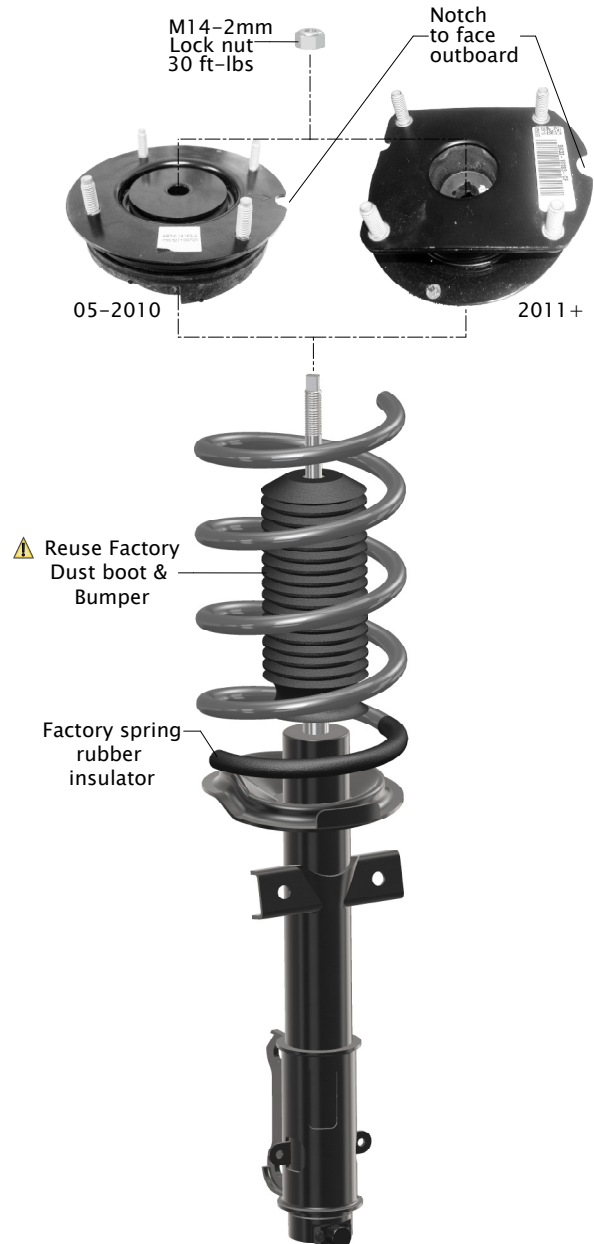

Notes:

S6009LM & S6011LM install identically
Ensure both spring ends seat properly against the mount stops.

Torque for the upper shock and strut nuts is provided as a reference since the nut is typically installed with a wrench.

Mustang Single Adjustable Steel Body Struts & Shocks

S6001EM with S6002CC79 & S6002CC90

S6005LM with S6002CC94

S6001 COIL-OVER KIT (sold per side)			
ITEM#	PART#	QTY	DESCRIPTION
1	S6001A	1	Coil-Over Tube Ø2.220 I.D.
2	S6001C	1	Spring Seat Jam Nut
3	S6001B	1	Spring Seat Nut
4	S6001D	1	Top Spring Seat
5	S4000N	1	Thrust Bearing
6	S4000M	2	Thrust Bearing Washer
7	S6001E	1	Thrust Bearing Cover

S6002CC79 & S6002CC90 CASTER CAMBER KIT			
ITEM#	PART#	QTY	DESCRIPTION
8	--	2	16mm ID flanged bushing
9	--	2	Stud Retainer Bracket
10	--	6	¼" Bearing Retainer Spacer
11	--	2	Bearing Retainer Bracket
12	--	2	Caster/Camber Plate
13	--	6	7/16" Washer
14	--	6	7/16"-20 Flanged Nut
15	--	4	3/8" Washer
16	--	4	3/8"-24 Screw
17	--	2	3/8" Spacer
18	S2041H	2	M16 x 2mm Nylon Locknut

S6002CC94 CASTER CAMBER KIT			
ITEM#	PART#	QTY	DESCRIPTION
19	--	2	Stud Retainer Bracket
20	--	2	14mm ID Flanged Bushing
21	--	2	Caster/Camber Plate
22	--	4	3/8" Washer
23	--	6	3/8"-16 Serrated Flange Locknut
24	--	2	3/8" Spacer
25	S2041H	2	M16 x 2mm Nylon Locknut

Caster/camber plate (item #12) is different for S6002CC79 & S6002CC90 kits. However, both are installed identically. Refer to pg. 3 to identify caster camber plate differences.

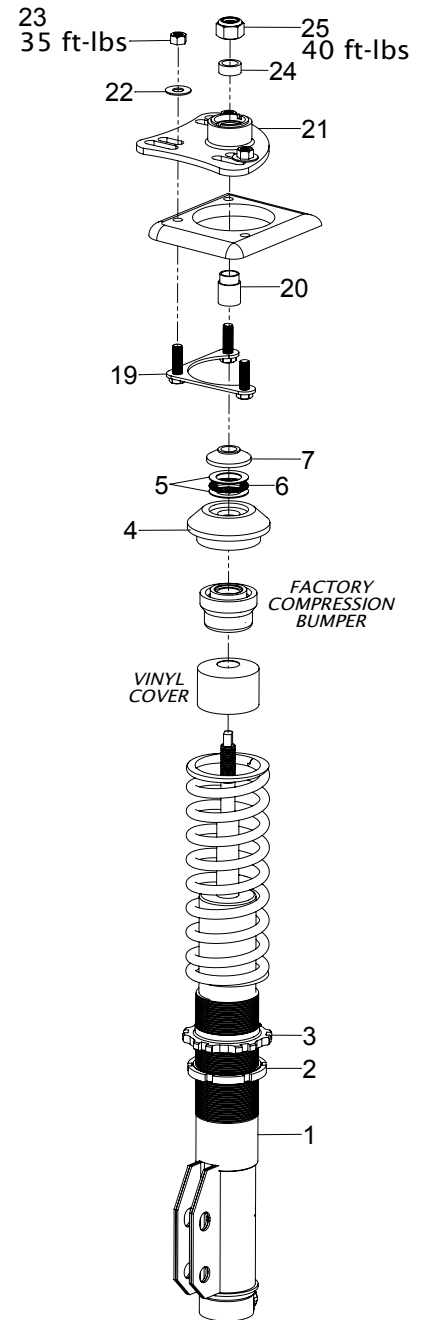
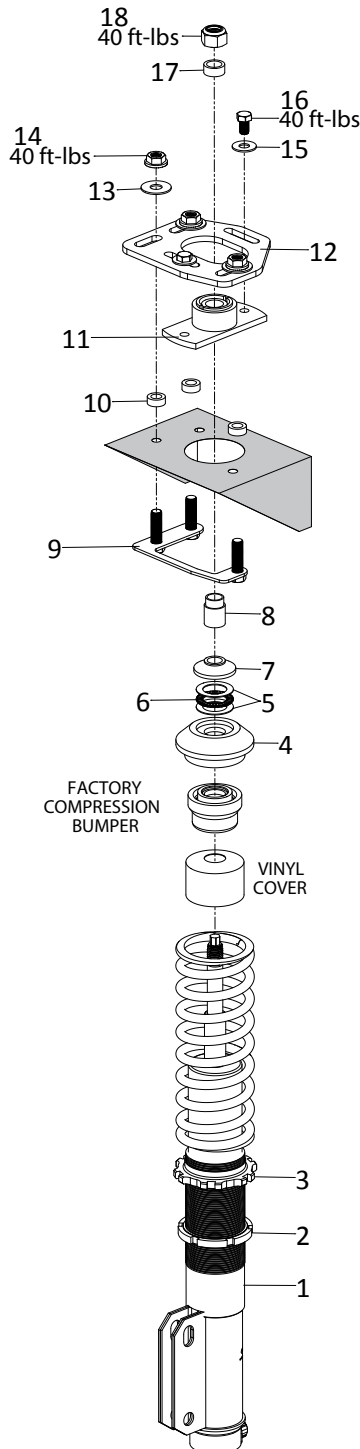

Mustang Single Adjustable Steel Body Struts & Shocks

*The following instructions are guidelines for installing caster camber kits and coil-over kits
Refer to the diagram on page 4 if using factory strut mount*

Note: *1994-04 applications may have the factory top alignment plate or mount riveted to the strut tower.
The rivets will need to be removed with a drill for installation of caster camber kits.*

Installation:

Steps 1-8 can be completed with the strut off the vehicle and pertains to all caster camber kits

1. Raise and support front of vehicle on a level surface using suitable equipment.
2. Consult the factory service manual to remove the factory strut.
3. Install the coil-over tube (1) by removing the vinyl cover from the strut and sliding the tube over the strut with the notch facing outboard to clear the strut mounting brackets. Reinstall the vinyl cover.
4. Reuse factory compression bumper.
5. Install the spring jam nut (2) followed by the spring seat nut (3) and spring.
6. Slide the top spring seat (4) over the strut piston rod .
7. Slide the thrust bearing assembly (5,6) over the piston rod followed by the thrust bearing cover (7).
8. Slide the stepped bushing (8/20) over the piston rod. Ensure smaller diameter faces up.

Steps 9-12 pertain to S6002CC79 and S6002CC90 kits

9. Place the bearing retainer bracket (11) under the caster/camber plate (12) and secure with the $\frac{3}{8}$ " screws and washers (15,16). Do not torque the screw.
10. Install the stud retainer bracket (9) on the underside of the strut tower.
11. Slide the $\frac{1}{4}$ " spacers (10) through the studs and against the top of the strut tower.
12. Slide the caster/camber plate and bearing retainer bracket assembly (11, 12) through the studs and against the spacers. Secure the assembly to the shock tower using the $\frac{7}{16}$ " nut and washers (13,14). Do not torque the nuts yet.

Steps 13-14 pertain to S6002CC94 Kkits

13. Install the stud retainer bracket (19) on the underside of the strut tower.
14. Slide the caster/camber plate (21) through the studs and against the shock tower. Secure the assembly to the shock tower using the $\frac{3}{8}$ " nut and washers (22,23). Do not torque the nuts yet.

The following steps pertain to all kits

15. Install the strut assembly by first installing the lower factory nuts and bolts. Then raise the lower control arm with a jack while aligning the strut shaft with the bearing in the caster/camber plate. Ensure the stepped bushings (8/20) slide into the bearing.
16. Slide the $\frac{3}{8}$ " thick spacer (17/24) over the strut piston rod and install the strut locknut (18/25). Torque the locknut (1) to 40 ft-lbs. Do not use an impact wrench. Damage to the strut internal components will result. Use a $\frac{7}{16}$ " wrench on the end of the piston rod to keep it from spinning.
17. A wheel alignment must then be performed to achieve the desired caster, camber, and toe in specifications. Once complete, ensure the final torque specification.

Mustang Single Adjustable Steel Body Struts & Shocks

WHEELALIGNMENTNOTES

A wheel alignment is required after the installation of these components. Alignments are possible to perform at home with proper tools, setup and careful measurements. Generally, the vehicle is set to stock alignment settings and adjustments are made accordingly to driver feedback. If the alignment is performed at a professional shop and any future adjustments to either ride height, camber, caster or toe are made note that these adjustments will effect other alignment settings and therefore it is recommended to get the vehicle re-aligned. Inspect tire wear often to ensure proper alignment. It is suggested to keep records of alignment settings for reference when making future adjustments. The bottom of this page can be used to do so.

RIDEHEIGHTADJUSTMENT

- Rotate the spring seat nut to the desired height
- Lock the spring seat in position with the jam nut

SPRING RATE & SUSPENSION NOTES

Spring rates depend drastically on the particular vehicle setup. Below are some general guidelines to follow when choosing a spring rate. Typically, 14" long springs are used with Strange Engineering struts and caster/camber kits. For drag race applications with rear wheel drive soft spring rates are used in the front suspension to encourage weight transfer. A softer spring rate can be compressed more by the constant weight of the vehicle than a stiff spring at identical length. Therefore, a soft spring will have more kinetic energy stored for weight transfer. If the weight transfer is excessive the rear tire sidewall may suffer drastic deformation and unload abruptly to result in tire shake. The front extension dampening adjustment can be increased to prevent this. If there is no weight transfer occurring the front extension dampening adjustment can be decreased or a softer spring rate can be used. For the vehicle to take full advantage of weight transfer a stiff rear spring will resist compression and maintain traction. However, a spring rate which is too stiff and does not compress will transfer the weight to the tire sidewall which will unload quickly and cause uncontrollable driving conditions. The end goal with all combinations of front and rear shock settings along with spring rates is to be able to plant the tires for maximum grip by increasing the footprint. However, increasing the footprint decreases the total diameter of the tire therefore, traveling a shorter distance in a single rotation. Also note that a taller and longer tire foot print is preferable for forward traction compared to merely a wide foot print. Track experience and careful documentation will result in the best combinations of strut and shock adjustment and springs.

DF

Camber _____

Toe _____

Caster _____

DR

Camber _____

Toe _____

Caster _____

PF

Camber _____

Toe _____

Caster _____

PR

Camber _____

Toe _____

Caster _____

Front Spring Rate _____

Front Spring Length _____

Rear Spring Rate _____

Rear Spring Length _____

Ride Height _____

Notes: _____

Mustang Single Adjustable Steel Body Struts & Shocks

Strut & Shock Dyno Graphs:

The following graphs show the average resistance of the shock extension (red) and compression (blue) forces as the shock velocity increases. Note that the adjustment control knob adjusts extension and slightly affects compression. Compression can not be adjusted independently of extension with single adjustable struts and shocks.

