

# Strange

## STRANGE LOW DRAG HUB KIT INSTRUCTIONS

**KIT #**  
B4181LD

**APPLICATIONS**  
Upgrade For GM COPO Camaro  
- Camaro - 2011 - 2019

### Features and Benefits:

Reduced Drag

- 0.5 inch lbs breakaway torque  
(One eighth of stock COPO breakaway)

Weight Reduction

- Almost 3 lbs less per side than stock
- Hubs are 5.8 lbs per corner

Precision Fit Angular Contact Ball Bearings

- Low drag bearings with minimal preload
- Lubricated with lightweight low viscosity oil

### KIT CONTENTS

ITEM#	PART#	QTY	DESCRIPTION
1	B4181F	2	Front Axle '16 Camaro
2	A1028B	10	1/2" Stripper washer
3	A1025A	10	1/2-20 X 2" HHCS
4	B4181K	2	SKF 17702 Seal
5	B4181I	2	SKF 7207 Ball bearing
6	B4181G	2	Hub Housing '16 Camaro
7	B4181J	2	SKF 7204 Ball bearing
8	S3400K	2	Dorman keyed washer
9	S3400H	2	Dorman Nut
10	S3400J	2	Stamped retainer
11	S3400L	2	Cotter pin
12	S3520F	2	#222 Buna O-ring
13	B4154E	2	Hub cap

### Installation instructions

1. Raise and support front of vehicle on a level surface using suitable equipment.
2. Remove wheel, stock disc, hub, and caliper from spindle.
3. Replace the stock hub with the hub provided. It comes pre-assembled. Fix the hub in place using the stock bolts, torquing them to 50 ft-lbs.
4. Slide the rotor over the wheel studs (3) flush to the face of the hub.
5. Attach the caliper to the existing caliper mount.

**Note:** Periodically check the flange (1) for play. If there is play then the hub will have to be removed and the spindle nut (9) will have to be retightened just till there is no perceived end play.

FIGURE # 2: Exploded B4181LD Assembly View

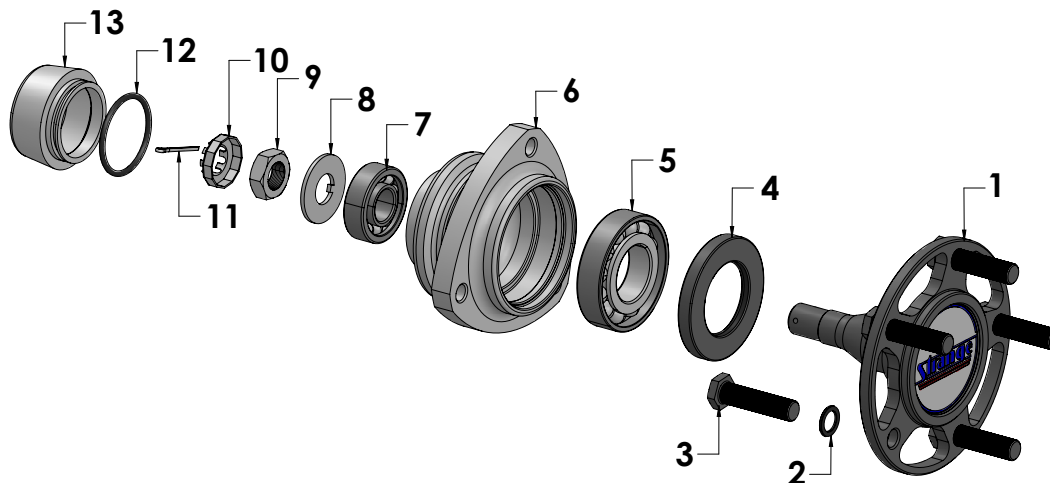

WARNING - RACING IS HAZARDOUS · STRANGE BRAKES ARE FOR LEGAL DRAG RACING ONLY

Disclaimer of Warranty – Purchasers using Strange Engineering racing components and equipment any and all inventory services, purchasers acknowledge that due to differing conditions and circumstances under which all equipment and parts are installed and used, purchasers are not relying on Strange Engineering Co. skill or judgment to select or furnish the proper part or equipment. Purchasers expressly affirm they are relying upon their own skill or judgment to select and purchase suitable goods.

Strange Engineering Co. makes no warranties whatsoever, expressed or implied, oral or written, to purchasers. There is no warranty of merchantability made to purchasers. Strange Engineering Co., further excludes any implied warranty of fitness with respect to racing and equipment, any and all inventory and service.