

# Strange

## HEAVY DUTY FRONT BRAKE KIT INSTALLATION INSTRUCTIONS

**KIT #**  
B4183WC  
B4183WC2

**APPLICATIONS**  
'86 - '87 C4 Corvette  
'91 - '96 Corvette

Strange Engineering brake kits are designed for **DRAG RACING ONLY**  
Modifications to the OEM upright are required for this kit.  
Semi-metallic brake pads (B5010) have 0.200" minimal thickness  
1.25" Steel brake rotors (B2795 & B2796) have 0.312" minimal thickness

Item #	Part #	Qty	Description
1	B4154E	2	Aluminum Hub Cap
2	S3520F	2	#222 Buna O-ring (Installed on B4154E)
3	S3400L	2	3/32" x 1.25" Cotter Pin
4	S3400J	2	Stamped Spindle Nut Retainer
5	S3400H	2	Dorman Spindle Nut (615-072)
6	S3400K	2	Dorman Key Washer
7	B1324E	2	Outer Hub Bearing Cone (Timken LM11949)
8	B2796	1	Left Hand HD/MD Tapered Rotor
9	B1320H	2	Inner Hub Bearing Cup (Timken LM67010 installed in B1324A)
10	B1324A	2	Front Hub "F" 4.75" B.C.
11	B1324D	2	Outer Hub Bearing Cup (Timken LM11910 installed in B1324A)
12	A1028B	10	1/2" I.D. Wheel Stud Washer
13	A1028A	10	1/2"-20 x 2.5" Wheel Stud
14	B1320J	2	Inner Hub Bearing Cone (Timken LM67048)
15	B1328B	2	Hub Seal (National 6815)
16	B1346B	8	7/16"-20 x 2-1/2" Caliper Bracket Bolt
17	B4180D	16	7/16" Washer
18	B1301E	4	3/8"-24 Press Nut (Installed in B4180A)
19	B4180A	2	Caliper Mount
20	B4180BCV	2	Corvette Spindle hub
21	S3402B	2	Stainless Spindle (Installed in B4180BCV)
22	B1346C	8	7/16"-20 Locknut
23	B5010	4	Organic 4-piston Caliper Pad
24	B5004	1	Left Hand 4-piston Caliper
25	P2316	2	1/8" NPT x -3AN Fitting (Installed in B5002, B5004)
26	B1301H	16	3/8" I.D. x 0.025" Thick Caliper Shim
27	B1301J	4	3/8" I.D. x 1/16" Thick Flat Washer
28	B5000Y	4	3/8"-24 x 1.125" Caliper Bolt
--	B5002	1	Right Hand 4-piston Caliper
--	B2795	1	Right Hand HD/MD Tapered Rotor

**FIGURE 1:**  
B4183WC Driver Side Corvette

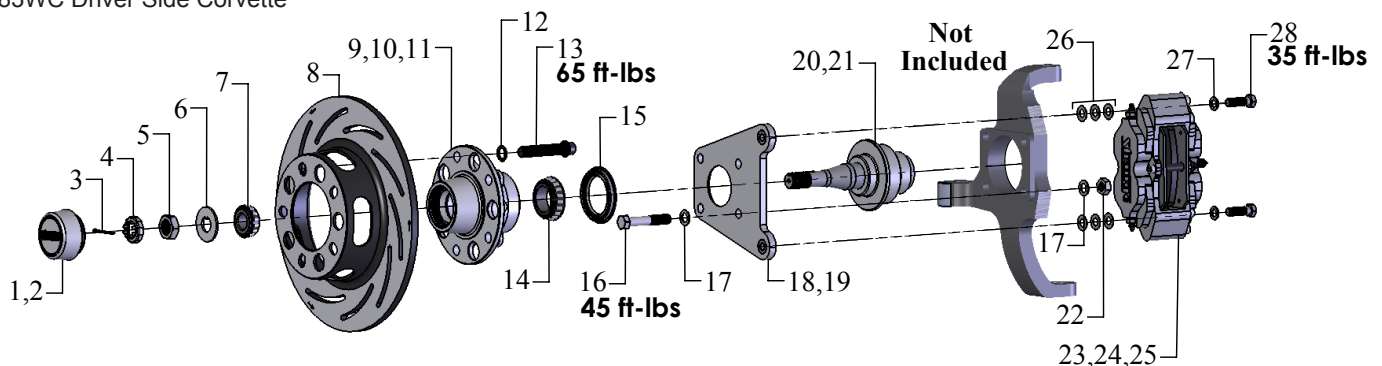

Read these instructions thoroughly and save for future reference.

If after reading these installation instructions, you have any questions or comments, please do not hesitate to call us.

## HEAVY DUTY FRONT BRAKE KIT INSTALLATION INSTRUCTIONS

**KIT #**  
B4183WC

**APPLICATIONS**  
'86 - '87 C4 Corvette  
'91 - '96 Corvette

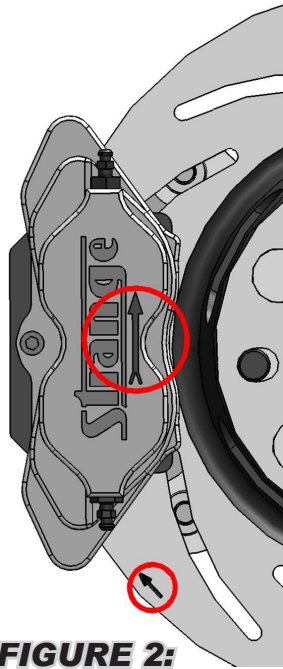

**FIGURE 2:**

1. Raise and support front of vehicle on a level surface using suitable equipment.
2. Remove wheel, caliper, rotor, hub, and brake line. Inspect all ball joints for excessive play and replace as needed.
3. Modify steering knuckle and spindle upright as shown in Figure #3 and Figure #4.
4. Slide the Strange spindle hub assembly (20,21) into the stock spindle upright.  
**Note:** Ensure the stock spindle upright bore is clean of surface rust for a proper slip fit.
5. Install the caliper mount (19) using the 7/16" caliper bracket bolts (16), 7/16" washers (17), and 7/16" locknuts (23) making sure the press nuts (18) are facing towards the rotor (8). Torque to 45 ft.-lbs.
6. Install 1/2" Dia. wheel studs (13) in front hub (10) using 1/2" I.D. wheel stud washer (12) and a small amount of BLUE Loc-tite®. Torque all studs to 65 ft.-lbs.  
**Note:** Consult your wheel and/or lug nut manufacturer for proper lug nut torque.
7. Pack inner (14) and outboard bearing cone (7) with NLGI 1 wheel bearing grease.  
**Note:** A bearing packer is recommended for this procedure; If one is not available work as much grease as possible into the cage and around the rollers.
8. Place inner bearing cone (14) into the front hub (10).
9. Press the hub seal (15) into the inboard side of the hub (10) flush to the outer face of the hub.
10. Slide the hub assembly onto the spindle then slide the outer bearing cone (7) into the hub (10).
11. Install the key washer (6) and the spindle nut (5).
12. Mount the wheel and tire assembly on the hub and snug the lug nuts.
13. While rotating the wheel, torque the spindle nut to approximately 20 ft.-lbs. Then, loosen the spindle nut until the wheel spins freely and there is no end play.
14. Install the stamped spindle nut retainer (4), cotter pin (3), aluminum hub cap (1), and remove the wheel and tire.

15. Slide the rotor (8) over the wheel studs flush to the face of the hub (10). **Note:** Slotted rotors mount with the arrow pointing in the direction of normal rotation (See Figure #2). - **Please read B1850 instructions for complete caliper instructions.**
16. Attach caliper (25) with the arrow facing in the direction of normal rotor rotation using 3/8"-24 caliper bolts (29) and 3/8" I.D. washers (28). Use 3/8" I.D. caliper shims (27) to center the caliper over the rotor, making sure pads contact the rotor evenly. The caliper bolt (29) should be fully engaged into the press nut. If the bolt is over engaged, use any remaining shims under the head of the bolt to prevent it from running into the rotor. Torque the caliper mounting bolts (29) to 35 ft.-lbs.  
**Note:** Because all spindles vary slightly you may not need the same amount of shim on both sides of the vehicle.
17. Connect the brake lines to the calipers. Calipers are tapped to 1/8"-27 NPT and supplied with -3AN fittings. Use proper adapters to connect them to existing lines or use new -3AN braided steel line (teflon lined). Bleed the calipers with DOT 4 or DOT 5.1 brake fluid **ONLY**.
18. A proper break in procedure is required to avoid brake fade and uneven rotor deposits from the pads. It consists of 8-10 brake applications increasing in harshness while allowing the brakes to cool slightly in between; do not keep the brakes applied between stops. After the last stop the brakes should be allowed to cool completely.

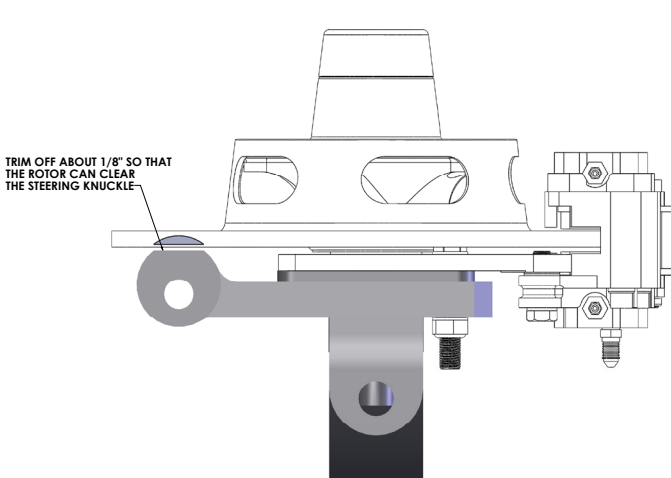

**FIGURE 3:**

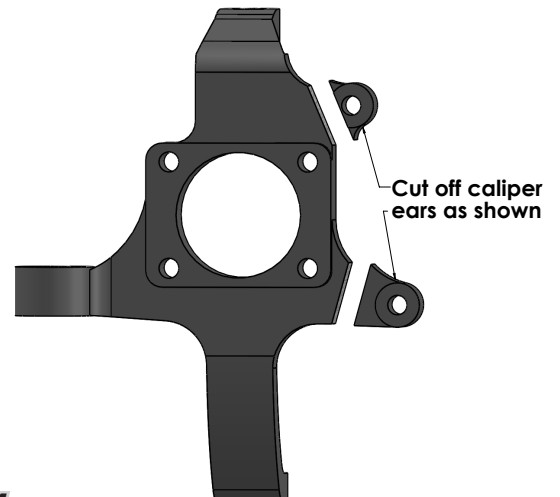

**FIGURE 4:**