

Strange

Kit Summary:

Kit #	P1020
Description	Strange two piece axle kits
Applications	Strange L5500SBB housing end
Page	1 of 4 total pages
Date Modified	Apr 11, 2019

RaceStrange

- High-misalignment double row spherical bearing and aluminum cartridge resists binding and prevents HP loss
- Gun-drilled 2-piece axle is lighter and stronger than traditional one piece axle
- Axle step captivates the axle bearing eliminating the need for a wedding ring
- Reduced wheel deflection

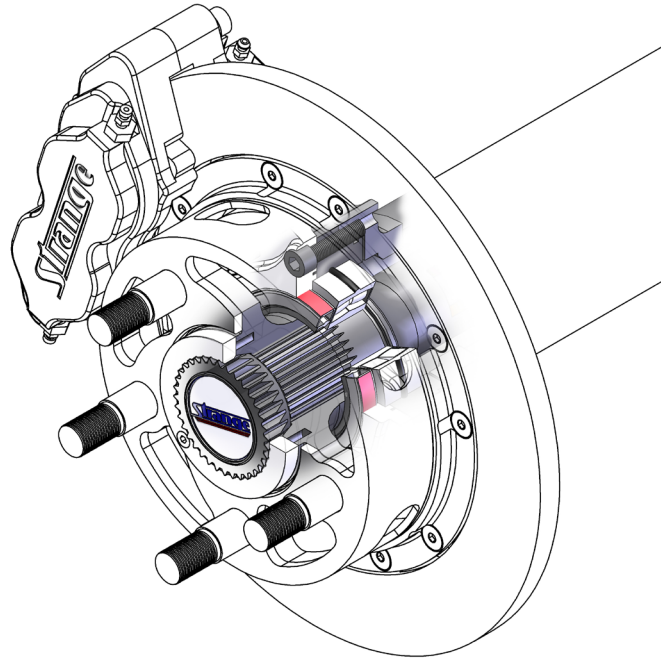

2-Piece axle kits

Kit	Brakes	Bolt circle
WJF4C	carbon	4-3/4"
WJF4S	steel	4-3/4"
WJF5C	carbon	5"
WJF5S	steel	5"

Bearing options

Kit	Brakes
WJMG	McGill spherical double row roller bearing
WJBB	Low friction ball bearing

Installation tools

Kit	Brakes
WJ11	Axle nut wrench
WJ13	40 spline axle vice holder

Brake gap

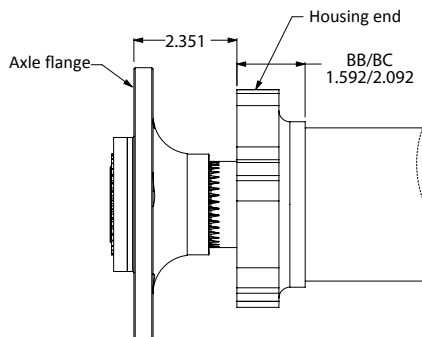

2-Piece axle kits

Kit	Brakes	Bolt circle
VZ123	40/45 Spline 2-Piece Axle	12.30"
VZ126	40/45 Spline 2-Piece Axle	12.72"
VZ132	40/45 Spline 2-Piece Axle	13.15"
VZ133	40/45 Spline 2-Piece Axle	13.41"
VZ135	40/45 Spline 2-Piece Axle	13.67"
VZ138	40/45 Spline 2-Piece Axle	13.90"
VZ142	40/45 Spline 2-Piece Axle	14.25"
VZ146	40/45 Spline 2-Piece Axle	14.75"
VZ150	40/45 Spline 2-Piece Axle	14.97"
VZ153	40/45 Spline 2-Piece Axle	15.30"
VZ155	40/45 Spline 2-Piece Axle	15.67"
VZ162	40/45 Spline 2-Piece Axle	16.10"
VZ163	40/45 Spline 2-Piece Axle	16.35"
VZ165	40/45 Spline 2-Piece Axle	16.62"
VZ168	40/45 Spline 2-Piece Axle	16.85"
VZ172	40/45 Spline 2-Piece Axle	17.25"
VZ176	40/45 Spline 2-Piece Axle	17.70"
VZ180	40/45 Spline 2-Piece Axle	17.91"
VZ203	40/45 Spline 2-Piece Axle	20.38"

ITEM#	PART#	QTY	DESCRIPTION
1	WJ08	2	Lock Collar
2	WJ04	2	2-Piece Axle Nut
3	WJ10	4	10-32 x 1/2" SHCS Bolt
4	-	2	40/45 Spline Gun-Drilled Axle (length to depend on application)
5	WJ02	2	1" Freeze Plug
6	A1RS	2	Strange Engineering Aluminum Decal
7	WJ12	4	10-24 x 5/8" SHCS Bolt
8	WJ01	2	Oil Seal
9	WJ00	2	McGill® High-Misalignment Bearing
Not Shown	WJBB	2	Low Friction Ball Bearing
10	WJ027	2	Bearing Cartridge
11	WJ028	2	-154 O-Ring (installed in WJ027)
12	B1301E	4	3/8"-20 Press Nut
13	WJ09	10	5/16"-24 x 1-1/4" SHCS Bolt
14	L5500SBB	2	Strange Housing End (1.592")
15	L5500SBC ²	2	Strange Housing End w/ added offset (2.092")
Not Shown	A1027D	10	5/8"-18 Lug Nut
Not Shown	A1027F	10	0.250" Aluminum Anti-Marring Spacer
16	A1037AM	10	5/8"-18 x 2.575" Wheel Stud
17	A1037D	10	5/8"-18 Thin Stover Jam Nut
18	WJ023	1	L.H. Axle Flange for 4-3/4" B.C. (WJF4C & WJF4S)
Not Shown	WJ029	1	L.H. Axle Flange for 5" B.C. (WJF5C & WJF5S)
Not Shown	WJ024	1	R.H. Axle Flange for 4-3/4" B.C. (WJF4C & WJF4S)
Not Shown	WJ030	1	R.H. Axle Flange for a 5" B.C. (WJF5C & WJF5S)
19	WJ036	2	-153 O-Ring (installed in caliper bracket)
20	S5000O	2	-033 O-Ring
21	WJ026	2	Ultra Carbon Caliper Bracket for 2-Piece Axle (WJF4C & WJF5C)
Not Shown	WJ032	2	Steel brake mounting caliper (WJF4S & WJF5S)

² To be used when replacing an existing housing end. To take the place of L5500SBB and to be determined when ordering

WJF4C Sub-assembly (driver's side)



Axle nut:

Torque axle nut to 250 ft-lbs.
Then increase torque until holes in the lock collar (1)
match two threaded holes in the flange.
Check and re-torque axle nut (2) periodically.

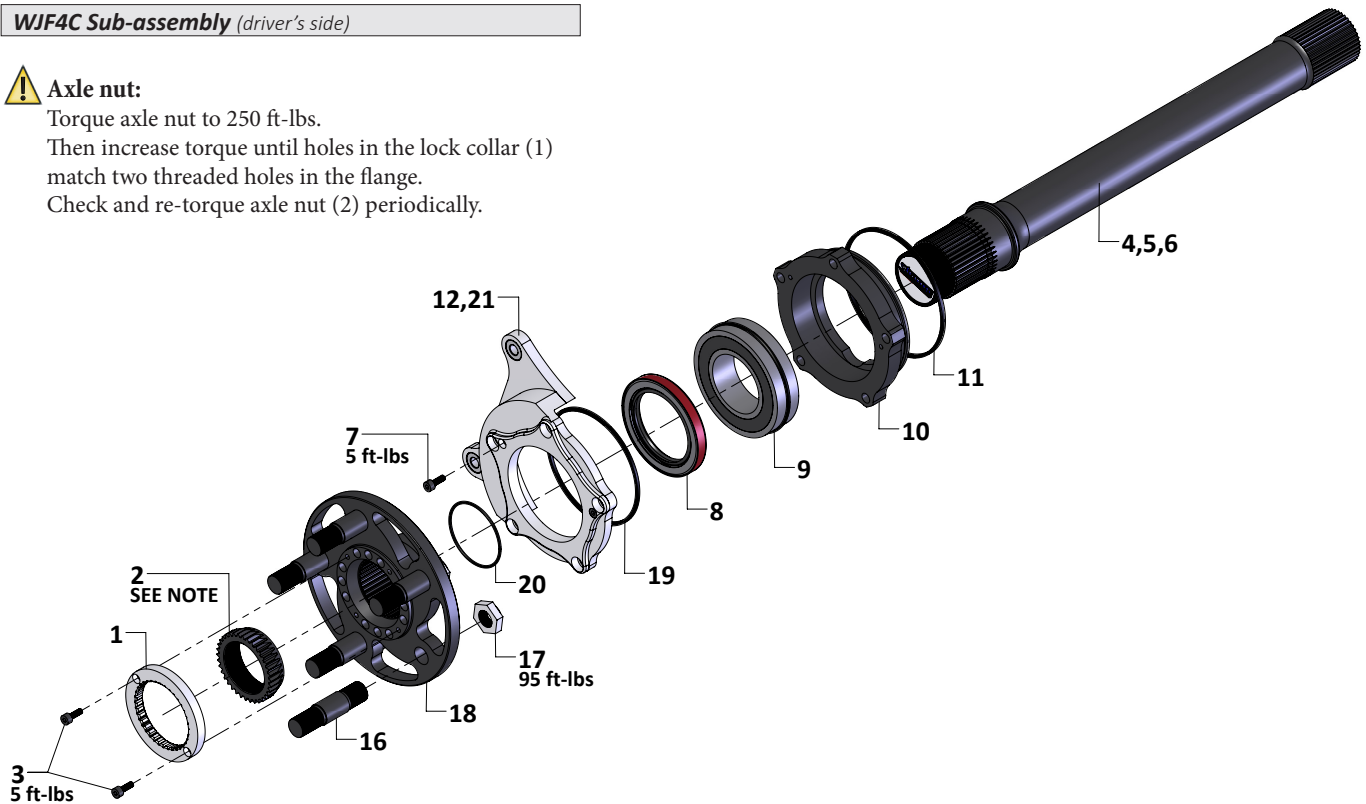

Components included in C18104NBUC & C18105NBUC carbon brake kits

ITEM#	PART#	QTY	DESCRIPTION
22	C1700D	20	¼-20 x ½" FHSCS
23	C1700H	2	11" Carbon Rotor Retaining Ring
24	C1790	2	11" Carbon Rotor
25	B5000Z	4	⅜-24 x 1.187" Caliper Mounting Bolt
26	B5042	2	4 Piston Brake Caliper (w/ 2 pc. insulated pistons)
27	L4050H1	2	Slotted (directional) 4-Piston Carbon Pad
28	L4050H2	2	Slotted (directional) 4-Piston Carbon Pad
29	P2316	2	⅛" NPT x #3 AN Fitting
Not Shown	C1700B	1	R.H. carbon rotor adapter for use with 4-¾" B.C. (C18104NBUC)
Not Shown	C1700F	1	R.H. carbon rotor adapter for use with 5" B.C. (C18105NBUC)
30	C1700C	1	L.H. carbon rotor adapter for use with 4-¾" B.C. (C18104NBUC)
Not Shown	C1700G	1	L.H. carbon rotor adapter for use with 5" B.C. (C18105NBUC)
31	S3402L	4	Flanged bushing

Components included in B1711NBM Pro Race steel brake kit:

ITEM#	PART#	QTY	DESCRIPTION
Not Shown	B2792	1	HD/MD R.H. Steel Rotor
Not Shown	B2793	1	HD/MD L.H. Steel Rotor
Not Shown	B5000Y	4	⅜"-24 x 1.125" HHCS Caliper Bolt
Not Shown	B1301J	4	⅜" I.D. Flat Caliper Washer
Not Shown	B1301H	16	⅜" I.D. x 0.025" Thick Caliper Shim
Not Shown	B5020	4	4-Piston Metallic Pad
Not Shown	B5002	1	R.H. 4-Piston Caliper
Not Shown	B5004	1	L.H. 4-Piston Caliper
Not Shown	P2316	2	⅛" NPT x #3AN Fitting (installed in B5002/B5004)

WJF4C with C18104NBUC (driver's side)

refer to Ultra Caliper instructions

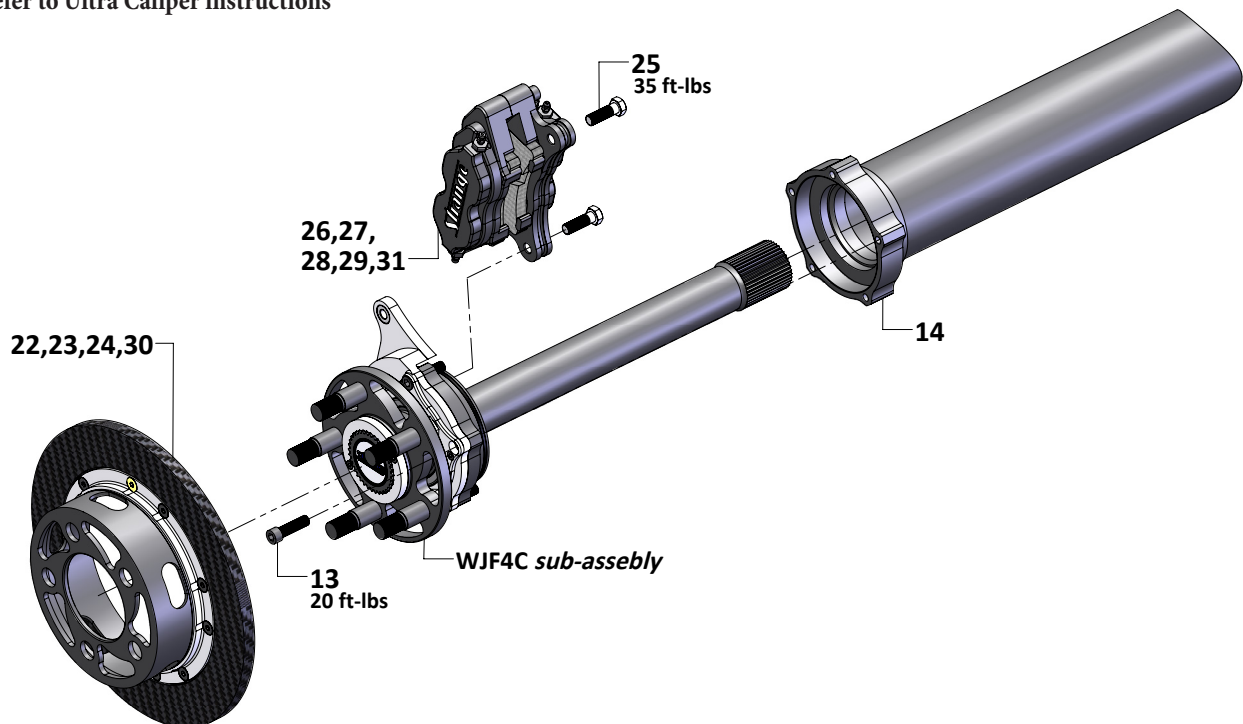

Installation instructions

- Instructions apply to all 2-piece axle kits, however, figures shown specifically cover WJF4C kit with C18104NBUC (ultra carbon brakes)
 - All two piece axle kits are shipped fully assembled as shown in figure 3. Refer to figure 2 for sub-assembly if service is required.
- 1 Slide the sub-assembly into the axle housing, ensuring that the bearing cartridge (10) lines up with the housing end.
 - 2 Turn the axle flange to allow for the five $\frac{3}{16}$ -24" x 1.25" bolts (13) to be threaded through the sub-assembly and into the housing end. Torque to 20ft-lbs.

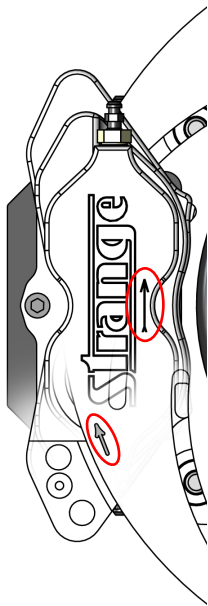

Steel brakes

- brake rotors and calipers mount with the arrow pointing in the direction of normal rotation
- refer to B1855 instructions for complete caliper installation

Break-in procedure

A proper break in procedure is required to avoid brake fade and uneven rotor deposits from the pads. It consists of 8-10 brake applications increasing in harshness while allowing the brakes to cool slightly in between; do not keep the brakes applied between stops. After the last stop the brakes should be allowed to cool completely.

Carbon brakes

- counter-bore on the brake rotor (24) must face outboard for the retainer (23) to seat properly
- refer to B5046 instructions for complete brake caliper installation

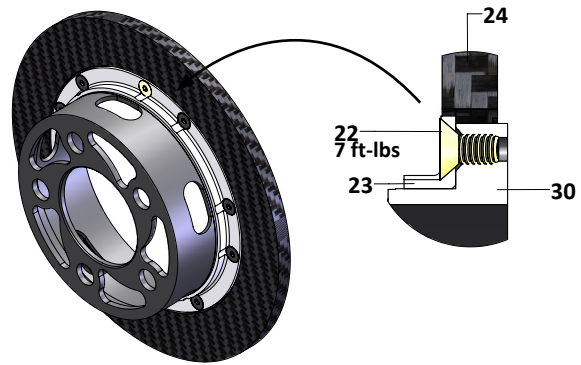

Axle sub-assembly removal from housing

- 1 Remove the $\frac{3}{16}$ -24 x 1- $\frac{1}{4}$ bolts (13)
- 2 Rotate the bearing cartridge (10) to misalign the points of the housing end (14)
- 3 Evenly tap on all five points of the bearing cartridge (10) as it's removed

Axle nut torque using optional tools

- 1 Securely locate the axle holder (WJ13) in a vice and insert 2-piece axle sub assembly
- 2 Using a $\frac{3}{4}$ " drive ratchet and 36 spline $\frac{3}{4}$ " wrench head (WJ11), tighten the axle nut
Torque to 250 ft-lbs
(Torque the axle nut past 250 ft-lbs, until the two sets of holes in the local collar line up with either pair of threaded holes in the axle flange)
- 3 Secure the lock collar using 10-32 x $\frac{1}{2}$ " bolts (3)
Torque to 5 ft-lbs

