

Installation
Instructions

Kit # B1720WC
Strange Pro Race Steel
Rear Brake Kit

Applications: 1993-98 Toyota Supra

BEFORE YOU BEGIN INSTALLATION:

Consult Directional Caliper Kit installation instructions to mount the brake caliper.
Consult pg. 112 of Strange Engineering catalog for available brake lines.
Inspect upper and lower ball joints for excessive play and replace as needed.
Consult factory service manual to remove and disassemble axle carrier and axle hub.
Brake rotors are shipped with an oil film on the surface to prevent rust and must be cleaned before installation.
Clean and inspect hub for damage (spun wheel bearings, stripped threads, etc.) and repair or replace as needed.
Read these instructions thoroughly and save for future reference.
If after reading these installation instructions, you have any questions or comments, please do not hesitate to call us.

Important Notes

- Strange Engineering brake kits are designed for **drag racing only**
- B5010 Semi-metallic brake pad minimal thickness is **0.200"**
- B2793/B2792 Steel brake rotor minimal thickness is **0.312"**
- Calipers are tapped to 1/8"-27 NPT and supplied with -3AN fittings
- B1720WC Pro Race Steel Brake Kit eliminates emergency brake

Kit Contents

Item #	Part #	Qty.	Description
1	B2793	1	Heavy Duty Brake Rotor Driver Side
2	B1720C	2	Brake Rotor Centering Spacer
3	B4182E	2	M12 x 1.75 x 50mm Long Caliper Mount Bolt
4	B1720A	1	Brake Caliper Mount Driver Side
5	B1301E	4	3/8-24 Press Nut (pre-installed in B1720A & B1720B)
6	B4182D	2	Brake Caliper Mount Spacer
7	B4152F	2	M12 x 1.75 Nylon Lock Nut
8	B1301H	16	3/8 I.D. x 0.025 Thick Caliper Shim
9	B5004	1	Brake Caliper Driver Side
10	B5010	4	Semi-metallic Brake Pads
11	B1301J	4	Caliper Bolt Washer
12	B5000Y	4	3/8-24 x 1.125" Caliper Mounting Bolt
13	B2792	1	Heavy Duty Brake Rotor Passenger Side
14	B1720B	1	Brake Caliper Mount Passenger Side
15	B5002	1	Brake Caliper Passenger Side



WARNING – RACING IS HAZARDOUS · STRANGE BRAKES ARE FOR LEGAL DRAG RACING ONLY

Disclaimer of Warranty – Purchasers using Strange Engineering racing components and equipment any and all inventory services, purchasers acknowledge that due to differing conditions and circumstances under which all equipment and parts are installed and used, purchasers are not relying on Strange Engineering Co. skill or judgment to select or furnish the proper part or equipment. Purchasers expressly affirm they are relying upon their own skill or judgment to select and purchase suitable goods. Strange Engineering Co. makes no warranties whatsoever, expressed or implied, oral or written, to purchasers. There is no warranty of merchantability made to purchasers. Strange Engineering Co., further excludes any implied warranty of fitness with respect to racing and equipment, any and all inventory and service.

Installation Instructions

Kit # B1720WC

Figure 1:
Directional
Caliper
& Rotors

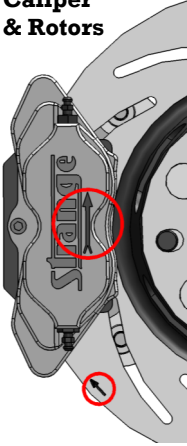

1. Slide the caliper mount bolt (3) through the mounting hole of the caliper mount (4).
2. Slide the caliper mount spacer (6) through the caliper mount bolt (3) to sit flush between the caliper mount (4) and surface of Toyota caliper ear.
3. Secure caliper mount (4) to the axle carrier body using the lock nut (7) and two original 8mm backing plate bolts. Torque the caliper mount bolt (3) to 50 ft-lbs. Torque the two original backing plate bolts to 19 ft-lbs.
 - **Note:** Remove any rust on mounting surfaces of Toyota caliper ear using wire brush or similar tools.
4. Refer to factory service manual to reassemble axle hub and axle carrier onto vehicle.
5. Slide the rotor centering spacer (2) over the hub center. **Ensure chamfer faces inboard.**
 - **Note:** Remove any rust on mounting surfaces of Toyota hub. Lug nuts can be installed to avoid damaging wheel stud threads while cleaning mounting surface.
6. Slide the rotor (1) over the wheel studs flush to the face of the hub.
 - **Note:** Slotted rotors mount with the arrow pointing in the direction of normal rotation. (See Figure # 1)
7. Attach the caliper (9) to the caliper mounting bracket (4) using the two caliper bolts (12) with flat washers (11) and shims (8). Torque caliper bolts (12) to 35 ft-lbs. (See Figure # 3)
 - **Notes:** The arrow on the caliper must face the normal rotation of the rotor/wheel. (See Figure # 1)
 - The number of shims (8) installed will vary because not all axle carriers are exactly identical.
 - Therefore, determine the proper amount of shims by positioning the caliper as closely as possible to the center of the rotor. Also, the passenger and driver side do not necessarily use the same amount of shims.

8. Connect the hydraulic lines to the calipers. Calipers are tapped to 1/8"-27 NPT and supplied with -3AN fittings. Use proper adapters to connect or use new -3AN braided steel line (teflon lined). Bleed the calipers with DOT 4 or DOT 5.1 brake fluid **ONLY**.
9. A proper break in procedure is required to avoid brake fade and uneven rotor deposits from the pads. It consists of 8-10 brake applications increasing in harshness while allowing the brakes to cool slightly in between; do not keep the brakes applied between stops. After the last stop the brakes should be allowed to cool completely.

Figure #2: Exploded View of B1720WC

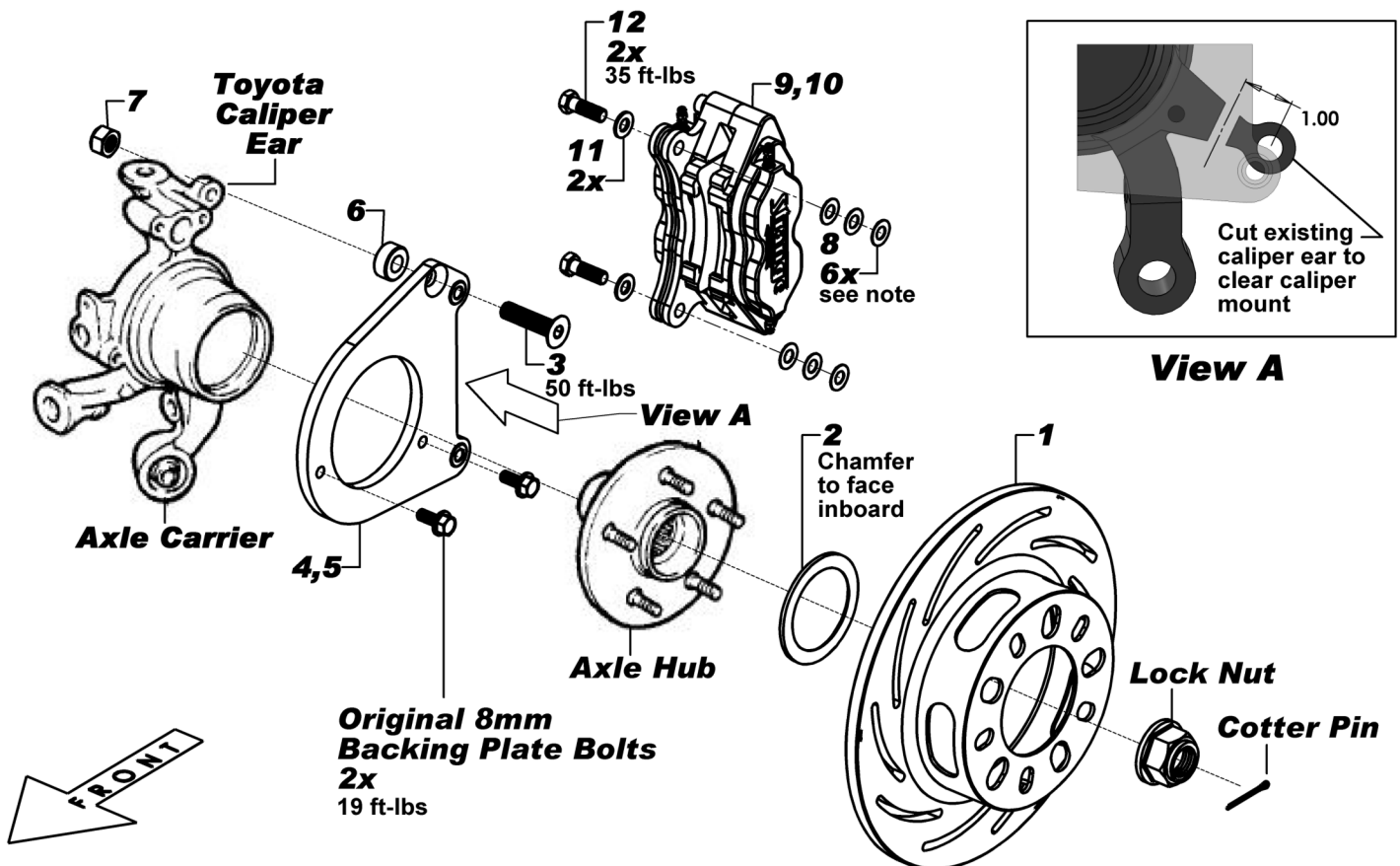

Note: Determine the proper amount of shims (8) by positioning the caliper as closely as possible to the center of the rotor.