



STRANGE S60 & 12-BOLT REAR END ASSEMBLY GUIDELINES & TORQUE SPECIFICATIONS

READ BEFORE INSTALLATION

Strange Engineering has always maintained a reputation of producing the highest quality components and assemblies. We have achieved this by accumulating input from you, the customer, and using that information to better ourselves as well as the products and services we offer.

Axle Replacement Policy

Alloy Axles (induction hardened 33 and 35 spline) are guaranteed against spline breakage to the original owner for a period of three years.

Strange pro race axles with 33,35 (excluding gundrilled) and 40 spline axles are guaranteed against spline breakage to the original owner for a period of five years.

Rear-end Assembly

Complete 12 bolt and Strange S-60 assemblies carry a one year parts replacement policy. All parts (except axles) installed in these assemblies are guaranteed against breakage for one year from the date of purchase.

Setup Specifications

S60 Carrier Bearing Preload Tighten adjuster nuts until they contact carrier bearings. Then tighten each adjuster nut 1 to 1-1/2 holes per nut to preload bearings. (Optional adjuster nut wrench H1109D is available)

S60 Pinion Preload with slightly oiled seal and new bearings is 30-35 in-lbs

S60 Total Backlash acceptable limit is 0.008"-0.010"

12-Bolt Carrier Bearing Preload Use a case spreader to add shims for preload. Do not spread case over 0.015".

12-Bolt Pinion Preload with slightly oiled seal and new bearings is 25-30 in-lbs

12-Bolt Total Backlash acceptable limit is 0.007"-0.010"

If using a crush sleeve, torque the pinion nut until proper pinion preload is achieved.

If the differential cover is removed, ensure to use either a gasket or gasket maker during reinstallation.

Gear Oil Type & Amount

SAE 85W-140 nonsynthetic gear oil is recommended

S60 & 12 Bolt require 2 quarts of gear oil

Note: If using Spool 2-1/2 quarts are required

Differential Friction Modifier

Differential friction modifier is required for clutch-type limited slip differentials.

One entire bottle (4 fl. oz.) is required in addition to the 2 quarts of gear oil.

GM or Spicer brand is recommended.

Additive is required even if gear oil manufacturer states oil is compatible with limited slip differentials.

Additive reduces clutch chatter in differential providing smoother more consistent operation.

Break-in Procedure for Street Gears

No harsh acceleration! Drive vehicle 50 miles. Allow 1/2 hour for cool down. Repeat for total of 250 miles.

At 500 miles remove the rear cover, fully clean assembly, use a fresh gasket and reinstall cover.

Storage of Rear End Assembly

Differential bearings, pinion bearings, and ring and pinion should be liberally oiled with gear oil and then sealed from the atmosphere in a plastic bag.

Disclaimer of Warranty

Strange Engineering reserves the right to make changes in design and to add or improve on its product without incurring any obligation to install the same on products previously manufactured.

Purchasers using Strange Engineering racing components and equipment, any and all inventory services, purchasers acknowledge that due to the differing conditions and circumstances under which all equipment and parts are installed and used, purchasers are not relying on Strange Engineering Co. skill or judgement to select or furnish the proper part or equipment.

Purchasers expressly affirm they are relying on their own skill or judgement to select and purchase suitable goods.

Strange Engineering Co. makes no warranties whatsoever, expressed or implied, oral or written, to purchasers. There is no warranty of merchantability made to purchasers. Strange Engineering Co. further excludes any implied warranty of fitness with respect to racing and equipment, any and all inventory and services.

STRANGE S60

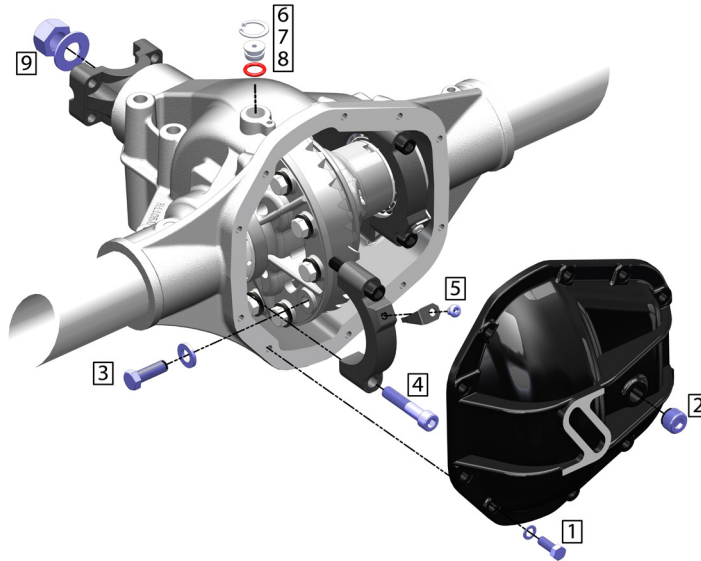

Item #	Part #	Description	Torque Spec.	Notes
1	D3517B	3/8-16 x 1.25" HHCS	35 ft-lbs	none
2	N1908E	1/2 NPT Pipe Plug	40 ft-lbs	Thread Sealer
3	D3504A	Ring Gear Bolt #40638	110 ft-lbs	Red Loctite
4	N1908F	1/2-13 x 2.50" SHCS	80 ft-lbs	Anti-seize
5	N1905B	5/16-18 x 0.375 BHSCS	10 ft-lbs	none
6	H1105Y	Plug Retainer	--	--
7	H1105X	Plug	--	--
8	H1105Z	Plug O-Ring	--	--
9	D3507	Pinion Nut	250 ft-lbs	Red Loctite

STRANGE 12-BOLT

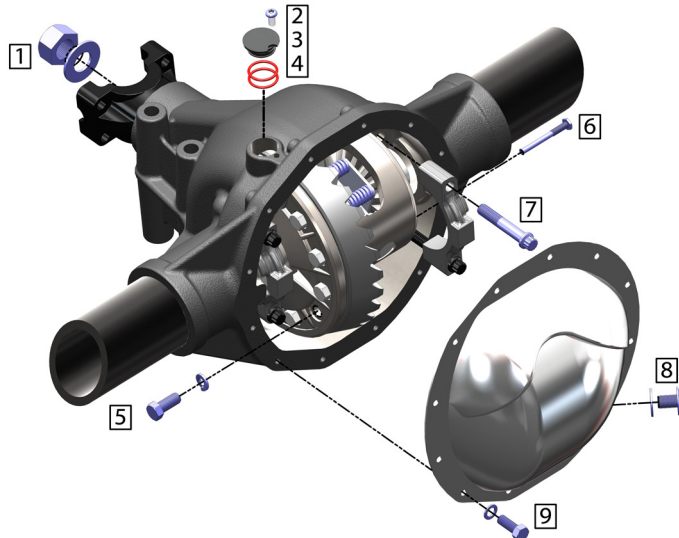

Item #	Part #	Description	Torque Spec.	Notes
1	R5214B	Pinion Nut	225 ft-lbs	Red Loctite
2	H1106T	1/4-20 x 0.50" BHSCS	7 ft-lbs	Anti-seize
3	H1106W	Sensor Plug	--	--
4	H1106U	Sensor Plug O-Ring (x2)	--	--
5	R5211E	3/8-24 x 7/8" HHCS	45 ft-lbs	Red Loctite
6	--	Differential Cross Pin Bolt	20 ft-lbs	Anti-seize
7	H1106C	7/16-14 x 2.50" 12 Pt. Bolt	65 ft-lbs	Anti-seize
8	--	1/2-20 Plug & Washer	15 ft-lbs	Thread Sealer
9	R5199B	5/16-18 x 3/4" HHCS	25 ft-lbs	none