

FORD MUSTANG 31 SPLINE C-CLIP AXLES

APPLICATIONS & KIT

P3110 - 94-98 OEM Mustang disc applications
 P3111 - 99-04 OEM Mustang disc applications
 P3112 - 05-14 OEM Mustang disc applications

| Kit Contents for P3110 & 3111 | | | |
|-------------------------------|---------|-------------|-----------------------------------|
| PART# | QTY | DESCRIPTION | |
| 1 | A3000RS | 2 | Register cap screw 5/16-18 x 3/4" |
| 2 | A3000S1 | 2 | Drum Brake Register |
| 3 | A1094S | 2 | Reluctor ring (optional) |
| 4 | A3299 | 2 | '94-'98 C-Clip axle (P3110) |
| 5 | A3306 | 2 | '99-'04 C-Clip axle (P3111) |

Note: Wheel studs must be installed prior to installing optional reluctor rings (Can use existing reluctor rings or purchase new ones)

1. If using ABS press the optional reluctor ring (3) onto the axle and press it against the circular face closest to the axle shaft and press it until it is fully seated against the radius of the axle. (As shown in Figure# 1).

Note: The flat face of the reluctor ring must face the axle flange.

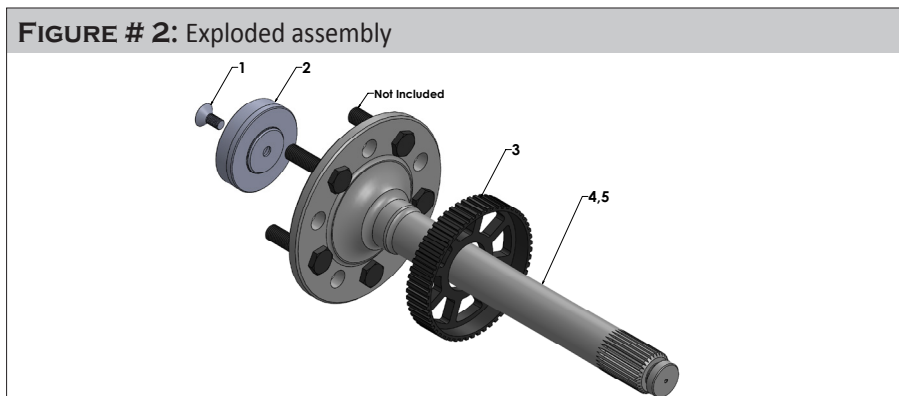
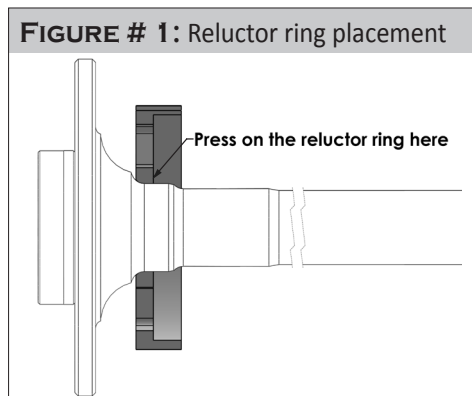

| Kit Contents for P3112 | | | |
|------------------------|---------|-------------|--|
| PART# | QTY | DESCRIPTION | |
| 1 | A3000RS | 2 | Register cap screw 5/16-18 x 3/4" |
| 2 | A3000S1 | 2 | Drum Brake Register |
| 3a | GA315 | 1 | '05-14' Mustang C-Clip axle (Driver) |
| 3b | GA325 | 1 | '05-14' Mustang C-Clip axle (Passenger) |
| 4 | B1105I | 2 | '05-14' Mustang C-Clip reluctor ring adapter |
| 5 | A1098I | 2 | Reluctor ring (optional) |

Note: Axles already come with a reluctor ring adapter pressed on.

Note: Wheel studs must be installed prior to installing optional reluctor rings. (Can use existing reluctor rings or purchase new ones)

1. If using ABS press the optional reluctor ring (5) onto the reluctor ring adapter(4) and press it against the small step until it touches the shoulder of the axle. (As shown in Figure# 1)

Note: The raised nose of the reluctor ring must face the axle flange.

