

Kit Summary:

Kit #	P1020
Description	Strange two piece axle kits
Applications	Strange L5500SBB housing end
Page	1 of 4 total pages
Date Modified	May 21, 2026

RaceStrange

- High-misalignment double row spherical bearing and aluminum cartridge resists binding and prevents HP loss
- Gun-drilled 2-piece axle is lighter and stronger than traditional one piece axle
- Axle step captivates the axle bearing eliminating the need for a wedding ring
- Reduced wheel deflection

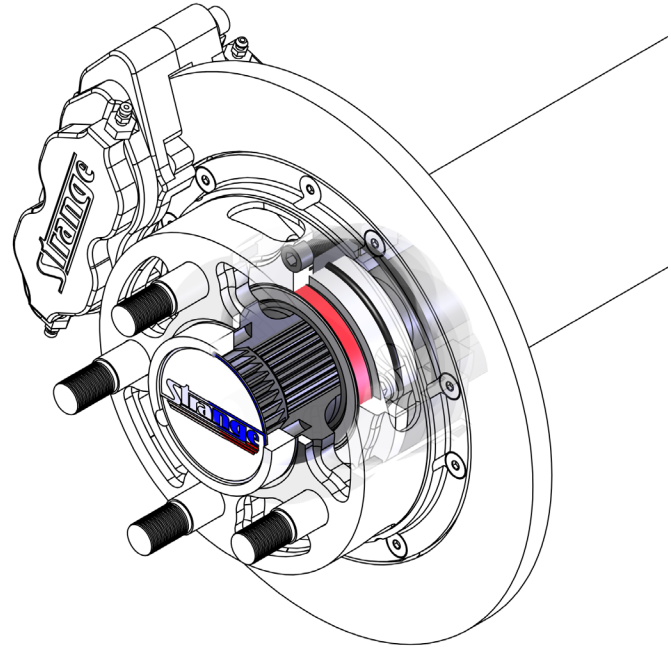

2-Piece axle kits

Kit	Brakes	Bolt circle
WJF4C	carbon	4-3/4"
WJF4S	steel	4-3/4"
WJF5C	carbon	5"
WJF5S	steel	5"

Bearing options

Kit	Brakes
WJBB	Low friction ball bearing

Installation tools

Kit	Brakes
WJ11	Axle nut wrench
WJ13	40 spline axle vice holder

2-Piece axle kits

Kit	Brakes	Axle Length
VZ133	40/45 Spline 2-Piece Axle	13.41"
VZ163	40/45 Spline 2-Piece Axle	16.35"

Part numbers listed above are stocked
Other Lengths can be made to order
- Call for more information -

Brake gap

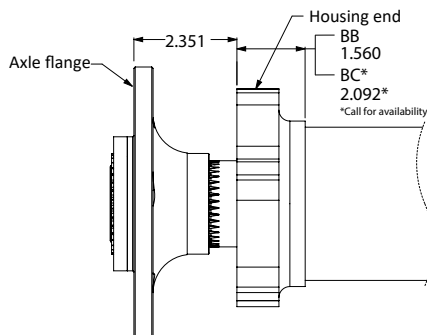

ITEM#	PART#	QTY	DESCRIPTION
1	WJ08	2	Lock Collar
2	WJ04	2	2-Piece Axle Nut
3	WJ10	4	10-32 x 1/2" SHCS Bolt
4	-	2	40/45 Spline Gun-Drilled Axle (length to depend on application)
5	WJ02	2	1" Freeze Plug
6	A1RS	2	Strange Engineering Aluminum Decal
7	WJ12	4	10-24 x 5/8" SHCS Bolt
8	WJ01	2	Oil Seal
9	WJBB	2	Low Friction Ball Bearing
10	WJ027	2	Bearing Cartridge
11	WJ028	2	-154 O-Ring (installed in WJ027)
12	B1301E	4	3/8"-20 Press Nut
13	WJ09	10	5/16"-24 x 1-1/4" SHCS Bolt
14	L5500SBB	2	Strange Housing End (1.560") (Not included)
15	L5500SBC ²	2	Strange Housing End w/ added offset (2.092") *Call for Availability
Not Shown	A1027D	10	5/8"-18 Lug Nut
Not Shown	A1027F	10	0.250" Aluminum Anti-Marring Spacer
16	A1037AM	10	5/8"-18 x 2.575" Wheel Stud
17	A1037D	10	5/8"-18 Thin Stover Jam Nut
18	WJ038	1	Axle Flange for 4-3/4" B.C. (WJF4C & WJF4S)
Not Shown	WJ029	1	L.H. Axle Flange for 5" B.C. (WJF5C & WJF5S)
Not Shown	WJ030	1	R.H. Axle Flange for a 5" B.C. (WJF5C & WJF5S)
19	WJ036	2	-153 O-Ring (installed in caliper bracket)
20	S5000O	2	-033 O-Ring
21	WJ026	2	Ultra Carbon Caliper Bracket for 2-Piece Axle (WJF4C & WJF5C)
Not Shown	WJ032	2	Steel brake mounting caliper (WJF4S & WJF5S)

² To be used when replacing an existing housing end. To take the place of L5500SBB and to be determined when ordering

WJF4C Sub-assembly (driver's side)

⚠ Axle nut:

Torque axle nut to 250 ft-lbs.
Then increase torque until holes in the lock collar (1)
match two threaded holes in the flange.
Check and re-torque axle nut (2) periodically.

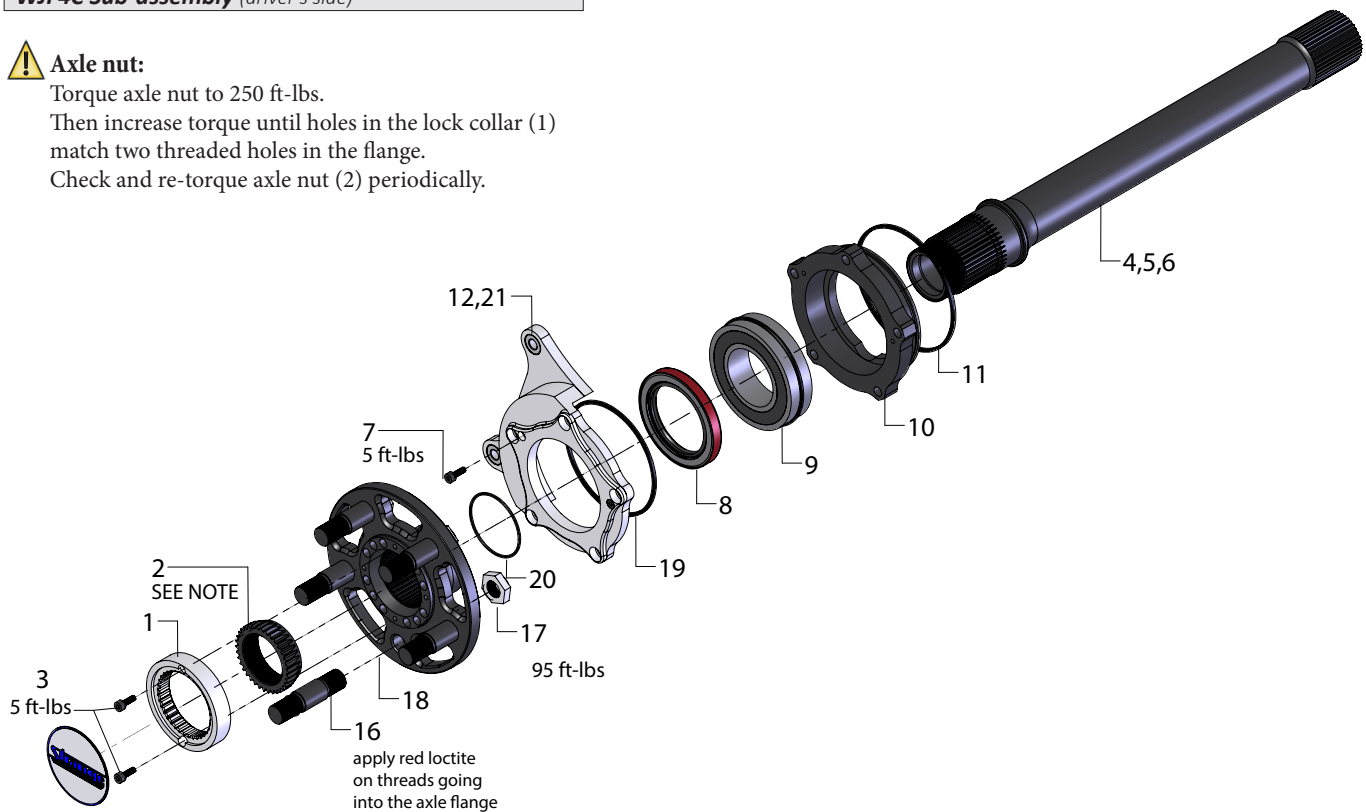

Components included in C18104NBUC & C18105NBUC carbon brake kits

ITEM#	PART#	QTY	DESCRIPTION
22	C1700D	20	¼-20 x ½" FHSCS
23	C1700H	2	11" Carbon Rotor Retaining Ring
24	C1790	2	11" Carbon Rotor
25	B5000Z	4	¾-24 x 1.187" Caliper Mounting Bolt
26	B5042	2	4 Piston Brake Caliper (w/ 2 pc. insulated pistons)
27	L4050H1	2	Slotted (directional) 4-Piston Carbon Pad
28	L4050H2	2	Slotted (directional) 4-Piston Carbon Pad
29	P2316	2	⅜" NPT x #3 AN Fitting
30	C1700M	1	Carbon rotor adapter for use with 4-¾" B.C. (C18104NBUC)
Not Shown	C1700K	1	Carbon rotor adapter for use with 5" B.C. (C18105NBUC)
31	S3402L	4	Flanged bushing

Components included in B1711NBM Pro Race steel brake kit:

ITEM#	PART#	QTY	DESCRIPTION
Not Shown	B2792	1	HD/MD R.H. Steel Rotor
Not Shown	B2793	1	HD/MD L.H. Steel Rotor
Not Shown	B5000Y	4	¾"-24 x 1.125" HHCS Caliper Bolt
Not Shown	B1301J	4	¾" I.D. Flat Caliper Washer
Not Shown	B1301H	16	¾" I.D. x 0.025" Thick Caliper Shim
Not Shown	B5020	4	4-Piston Metallic Pad
Not Shown	B5002	1	R.H. 4-Piston Caliper
Not Shown	B5004	1	L.H. 4-Piston Caliper
Not Shown	P2316	2	⅜" NPT x #3AN Fitting (installed in B5002/B5004)

WJF4C with C18104NBUC (driver's side)

refer to Ultra Caliper instructions

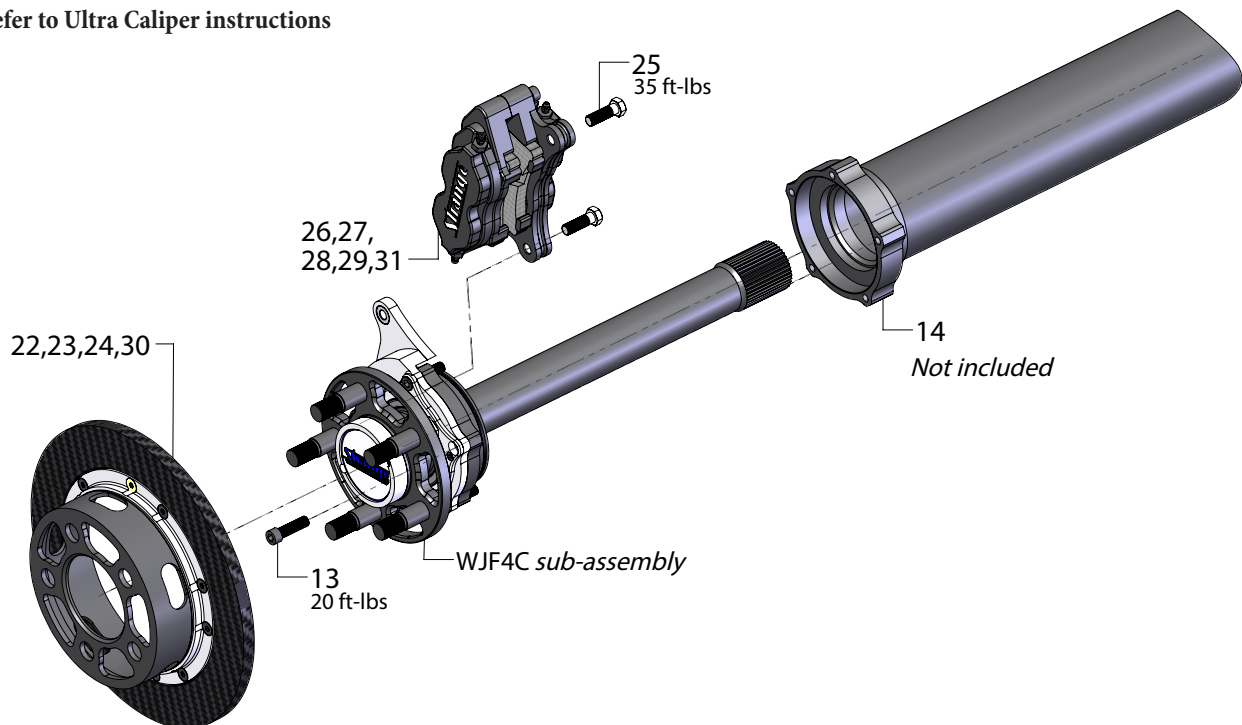

Installation instructions

- Instructions apply to all 2-piece axle kits, however, figures shown specifically cover WJF4C kit with C18104NBUC (ultra carbon brakes)
 - All two piece axle kits are shipped fully assembled as shown in figure 3. Refer to figure 2 for sub-assembly if service is required.
- 1 Slide the sub-assembly into the axle housing, ensuring that the bearing cartridge (10) lines up with the housing end.
 - 2 Turn the axle flange to allow for the five $\frac{3}{16}$ -24" x 1.25" bolts (13) to be threaded through the sub-assembly and into the housing end. Torque to 20ft-lbs.

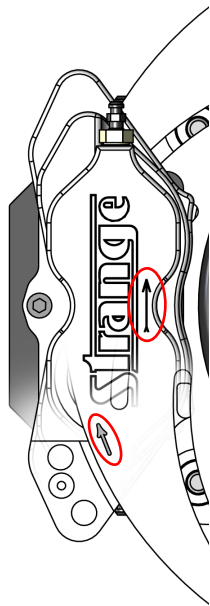

Steel brakes

- brake rotors and calipers mount with the arrow pointing in the direction of normal rotation
- refer to B1855 instructions for complete caliper installation

Break-in procedure

A proper break in procedure is required to avoid brake fade and uneven rotor deposits from the pads. It consists of 8-10 brake applications increasing in harshness while allowing the brakes to cool slightly in between; do not keep the brakes applied between stops. After the last stop the brakes should be allowed to cool completely.

Carbon brakes

- counter-bore on the brake rotor (24) must face outboard for the retainer (23) to seat properly
- refer to B5046 instructions for complete brake caliper installation

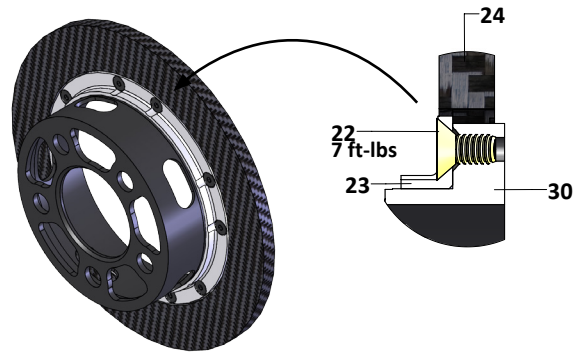

Axle sub-assembly removal from housing

- 1 Remove the $\frac{3}{16}$ -24 x 1- $\frac{1}{4}$ bolts (13)
- 2 Rotate the bearing cartridge (10) to misalign the points of the housing end (14)
- 3 Evenly tap on all five points of the bearing cartridge (10) as it's removed

Axle nut torque using optional tools

- 1 Securely locate the axle holder (WJ13) in a vice and insert 2-piece axle sub assembly
- 2 Using a $\frac{3}{4}$ " drive ratchet and 36 spline $\frac{3}{4}$ " wrench head (WJ11), tighten the axle nut
Torque to 250 ft-lbs
(Torque the axle nut past 250 ft-lbs, until the two sets of holes in the local collar line up with either pair of threaded holes in the axle flange)
- 3 Secure the lock collar using 10-32 x $\frac{1}{2}$ " bolts (3)
Torque to 5 ft-lbs

