

Strange

Engineering

8300 North Austin Avenue · Morton Grove IL 60053 · 847-663-1701 · Fax 847-663-1702 ·

INSTALLATION, ASSEMBLY, AND SERVICE INSTRUCTIONS FOR SINGLE & DOUBLE ADJUSTABLE MAX EXTENSION STRUTS

<u>Kit Part#</u>	<u>Stroke (in.) (With bump rubber installed)</u>	<u>Adjustability</u>
S3520	6.50	Extension
S3520DBL	6.50	Extension & compression

BEFORE YOU BEGIN INSTALLATION: Strange Engineering Max Extension struts and associated brakes are for **DRAG RACING ONLY!** The basic guidelines for strut geometry are covered, however, a professional and qualified chassis shop should perform the welding to ensure correct alignment of the front end and sufficient weld integrity. In addition, assembly should be performed by a professional & qualified mechanic. Read these instructions thoroughly and save for future reference. If after reading these installation instructions, you have any questions or comments, please do not hesitate to call us.

INTRODUCTION: Strange Engineering Max Extension struts provide the basis for a lightweight front suspension that is popular for all types of Sportsman cars. Chassis construction is much simpler, suspension geometry is more easily established, and header clearance is improved over conventional A-arm suspension. In addition, Strange strut suspension systems offer a reduction in front vehicle weight. Compared to a lightweight tubular A-arm suspension, a savings of at least 15 lbs. can be expected.

FEATURES & BENEFITS: The main body of the Max Extension strut is forged out of high strength 2014-T4 aircraft aluminum, furthermore, every strut body is liquid penetrant inspected before assembly ensuring you the safest strut in drag racing. Camaro size spindle shafts made from heat treated 17-4 stainless steel provide an exceptionally strong foundation for wheel and hub mounting. Fatigue resistant steel steering arms can be formed easily to obtain proper steering geometry. Brake mounting bosses are an integral part of the forged strut body, providing simplicity for Strange brake kit mounting on either side of the strut.

STRUTS WITH LIGHTWEIGHT BRAKE KITS: Direct or lightweight brake kits are designed for spindle mount wheels. These wheels utilize an integrated hub assembly. Only one large nut holds the wheel to the strut. It allows the strut to be mounted closer to the wheel compared to the five lug hub mount type. Due to the limited size of the brakes, this system should only be used with vehicles weighing no more than 2,600 lbs. and deploying a parachute. Otherwise, premature pad wear and rotor warpage may occur.

STRUTS WITH MEDIUM DUTY OR HEAVY DUTY BRAKE KITS: Heavy duty and medium duty brake kits are designed for typical five lug bolt-on style wheels. Medium duty is recommended for vehicles weighing up to 2,600 lbs. and heavy duty brakes are recommended for vehicles exceeding 2,600 lbs. The strut package is designed to be used with a 4-3/4" bolt circle wheel. We can accommodate a 4-1/2" bolt circle; however, it must be specified at the time the order is placed.

CUSTOM VALVING: Max Extension struts have a wide range of adjustability, however, if you prefer to have lighter or stiffer than normal strut valving for compression or extension, we can change the valving range utilizing our in house strut/shock dyno. Dyno checking is also useful to ensure that older struts are performing properly and to provide feedback as to how the struts are currently adjusted. Contact Strange for pricing and/or additional information in regard to dyno checking and revalving.

CUSTOM LENGTHS AND STROKES: Custom shorter extended and compressed lengths are available as well as custom shorter strokes. Call Strange to discuss application and pricing.

MAINTENANCE: Regular maintenance would include a yearly inspection of wheel bearings and seals. Check the lower control arm ball assembly for excessive play. Look for any leakage of fluid where the shaft enters the strut body. With the strut at full extension, rock the shaft back and forth. The shaft is least supported in this position so wear would be most evident in this condition. Expect a little play, but anything seeming excessive should sent in for inspection. Also, check all fasteners to be sure they are torqued to proper specifications.

COMMON COMPONENTS BETWEEN BOTH KITS

<u>Item#</u>	<u>Part#</u>	<u>Qty.</u>	<u>Description</u>
1	F1282	8	3/8"-24 Jet nut
2	S3400H	2	Spindle nut
3	S3400J	2	Stamped spindle nut retainer
4	S3400K	2	Spindle key washer
5	S3400L	4	Cotter pin
6	S3400M	2	Thrust bearing
7	S3400N	4	Thrust bearing races
8	S3400Z	2	Ball joint stud castle nut
9	S3402B	2	Stainless steel strut spindle (Pressed into strut body)
10	S3402C	2	Steering arm
11	S3402D	2	Spring seat nut
12	S3402E	2	Jam nut
13	S3402G	2	Ball joint stud
14	S3402I	2	Ball joint stud washer
15	S3402L	4	Steering arm bushing (Pressed into strut body)
16	S3402M	2	Flanged ball joint stud washer
17	S3402Q	8	3/8"-24 bolt
18	S3403C	2	1-7/8" O.D. polyurethane cushion
19	S3403D	2	1-3/4" O.D. polyurethane cushion
20	S3403E	2	11/16 I.D. flat washer
21	S3403G	2	Flanged lock nut
22	S3520B	2	Spring perch
23	S3402N	8	3/8" AN washer
24	S3403B	2	Top spring retainer
25	S3800A1562	2	Piston rod
26	S3800C2	2	Gland nut
27	S3800K	2	Hex adjuster knob
28	S3600W	2	Compression bumper

COMPONENTS INCLUDED IN S3520 KIT:

<u>Item#</u>	<u>Part#</u>	<u>Qty.</u>	<u>Description</u>
29	S3402F	2	Forged aluminum strut body
30	S3520A	2	Strut extension tube

COMPONENTS INCLUDED IN S3520DBL KIT:

<u>Item#</u>	<u>Part#</u>	<u>Qty.</u>	<u>Description</u>
Not shown	S3402DBL	2	Forged aluminum double adjustable strut body
Not shown	S3520AA	2	Double adjustable extension tube
Not shown	S3602F	2	Compression adjuster
Not shown	S3602E	2	Aluminum cap for compression adjuster

NOTE: Internal strut components are not listed because they are only serviceable by Strange Engineering

MAX EXTENSION STRUT LOWER CONTROL ARM END ASSEMBLY (S3751)
(NOT INCLUDED WITH COMPLETE STRUT KITS)

<u>Item#</u>	<u>Part#</u>	<u>Qty.</u>	<u>Description</u>
31	S3400X	2	Spirolok
32	S3400Y	2	Spherical bearing
33	S3520E	2	Control arm end

FRONT END GEOMETRY: The following are suggested parameters for setting up the front end geometry for all Max Extension struts:

Caster - 6-10 deg.

Camber - 0 deg.

Toe in - 1/16" total measured at the wheels

Kingpin angle - 10 deg. (built into the strut)

When setting up the strut for the car it should be at ride height using the information in Table #1. For example, the strut would be fully compressed, then extended 2" to achieve ride height of the strut with the car also at ride height.

The mounting points on the frame for the lower control arms are as follows. The rear lower control arm should **NEVER** be attached to the frame in-line or in front of the strut spindle shaft. It should be mounted as far towards the back of the vehicle as practical or approximately 1-3/4" behind the strut spindle shaft. When viewed from the front of the car, the rear lower control arm should angle 5 deg. (+/-5 deg.) down going from the strut towards the center of the car.

The mounting point for the front lower control arm should be about 14" in front of and 1/4" lower than the rear lower control arm mounting point. Both front and rear lower control arms should be cut to the proper length depending on geometry required, frame design, track width, etc.

The steering tie rods should be parallel to the plane of the lower control arms. This will provide for the minimum amount of bumpsteer. The rod end connected to the strut steering arm may be mounted to the top or bottom of the steering arm to help accomplish this. Check to be sure that wheel clearance is not a problem. Also, the steering arms can be bent to achieve proper geometry. If they do need to be bent it is recommended to weld on gussets to strengthen them. The steering arms are made out of ASTM A36 material (Very similar to AISI 1018) which is easily weldable.

WELDING: The control arm end is manufactured from 4130 chromoly steel. The only welding method we recommend is TIG welding using a mild steel rod or 4130 steel rod. **WARNING - IT IS NOT RECOMMENDED TO USE STRUT AS A WELDING FIXTURE - SERIOUS INTERNAL DAMAGE MAY OCCUR.** If no other option is available be sure to attach the ground clamp to the chassis as close as possible to the area being welded. Before final welding the front end should be mocked up by tack welding the assembly together. Install the strut without the spring and bump rubber and fully extend and compress to ensure that there is not any binding with any of the rod ends or spherical bearings. Once proper alignment is verified final welding should be completed for all mounts and lower control arms.

ADJUSTING RIDE HEIGHT: Ride height is adjusted by rotating the spring seat nut (11) located underneath the spring. Once the ride height is set, the jam nut (12) is tightened to lock the spring seat in place. Do not alter the height of the bump rubber to change ride height or stroke. Severe damage to internals will result.

ADJUSTING SINGLE ADJUSTABLE STRUTS (S3520): The compression valving is non-adjustable. The extension valving is adjusted by rotating a 3/8" hex knob at the top of the strut. Turning the knob clockwise decreases dampening and turning it counter-clockwise increases dampening. You will not hear any "clicks" while adjusting the dampening. The range of adjustment is approximately 3-1/8 turns. **DO NOT FORCE THE ADJUSTER** - it may already be fully adjusted in either direction. The internal components can be damaged if excessive force is used. A recommended starting point would be one turn from the full soft position.

ADJUSTING DOUBLE ADJUSTABLE STRUTS (S3520DBL): On extension the double adjustable struts will adjust the same way as the single adjustable struts. The compression adjustment is located near the bottom of the strut and adjustments are made using a slotted screwdriver. 13 positions or 12 "clicks" are available from full soft to full stiff. Rotating the adjuster clockwise will increase dampening and counter-clockwise will decrease dampening. A recommended starting point would be four clicks from full soft.

VEHICLE TRANSPORT: Limiting chassis movement while trailering is very important. An unsecured race car will experience the same mileage as the tow vehicle. A fifty mile drive to the track, and the car's struts have already experienced two hundred passes. The situation is even worse considering these are bumpy passes. Not securing the struts could drastically shorten the life of the internal components causing premature rebuilding.

STRUT DIMENSIONS: See Figure #1 and Table#1 below for Max Extension strut dimensions.

Figure #1 (Note: Shown with five lug hub and heavy duty brakes)

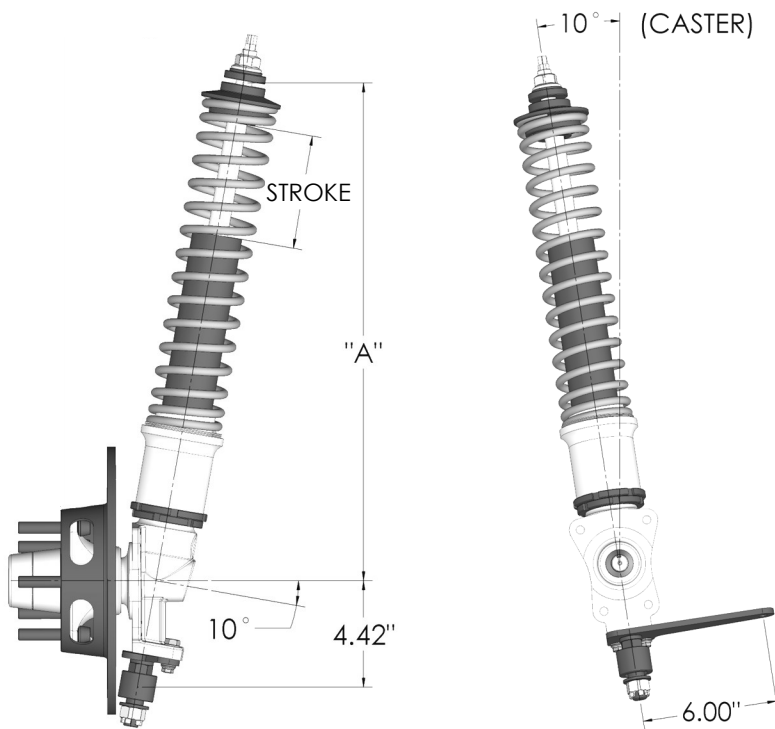

Choice Of Valving for Double Adjustable

- ZF1**
- No Prep (Back side)
 - Super Gas
 - Cars needing more weight transfer

- ZF5**
- Base valving (Most common)
 - Bracket cars
 - No Prep (Front side)
 - ASAG (All Steel / All Glass)

- ZF10**
- Top Sportsman
 - Mountain Motor
 - X275 and similar radial classes
 - Pro Mod
 - RVW
 - Import (Front Wheel Drive)
 - Stick Shift

Table #1

			"A"		
Adjustment	Stroke	Spring Length	Extended	Ride Height	Compressed
Single & Double	6.30"	14" with perch	22.70"	17.75 - 19.25"	16.30"
Double	6.30"	14"/12" with perch	20.9"	16.00" - 17.5"	14.50"
	4.70"	14" without perch	17.70"	14.25" - 15.25"	12.90"
	3.70"	12" without perch	11.50"	12.50" - 13.25"	11.50"

STRUT ASSEMBLY: Figure #2 shows an exploded view of S3520 strut kit

- 1.) All Max extension struts come from Strange Engineering with all the internals assembled and some of the external components are assembled for your convenience.
- 2.) When attaching the top of the strut to the frame, tighten the top nut (21) until the polyurethane cushions (18, 19) just begin to compress. This will allow the strut to pivot slightly without binding or having a sloppy fit. **DO NOT USE AN IMPACT WRENCH TO TIGHTEN THE TOP NUT.** Damage to the adjuster or the internals may occur. The proper way to tighten the top nut is to thread the nut on as far as possible by hand, then hold the top of the piston rod with a 7/16" wrench and finish tightening the nut. **DO NOT HOLD ON THE ADJUSTER WHEN TIGHTENING THE NUT.**
- 3.) When installing the steering arm (10), ball joint stud washer (14), and ball joint stud (13), make sure that the large chamfer on the I.D. of the washer faces the ball joint stud and not the steering arm.
- 3.) Refer to specific brake kit instructions when installing brakes, however, hardware (1,17,23) is included in the strut kit for mounting the caliper mount to the strut body. Also refer to brake kit instructions when installing spindle nut hardware.

Item#	Description	Torque (ft.-lbs.)
8	Ball joint stud castle nut	40-45
13	Ball joint stud	100-110*
17	3/8"-24 bolt	35-40
21	Flanged lock nut	(See instructions)

* Apply blue Loctite to the ball joint threads before installing into the aluminum strut body

