

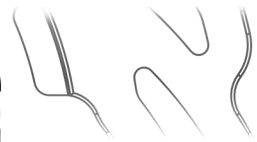

# Strange



## EVOLUTION 2-PISTON DDM FRONT BALL BEARING BRAKE KIT INSTRUCTIONS

**KIT #**  
B4710WCE - Early GM  
brake kit for drum spindles

**APPLICATIONS**  
1973-1974 Apollo, 1967-1969 Camaro/Firebird  
1967-1972 Chevelle / Malibu / El Camino  
1966-1974 Chevy II / Nova  
1967-1972 Cutlass, 1970-1972 Monte Carlo  
1973-1974 Omega, 1971-1974 Ventura

### Evolution Rotors

- Dynamic Drive Mount (DDM) system secures the rotor and allows for rotor thermal expansion
- DDM system design is secured by an internal Spirolok, eliminating heavy bolts and hardware
- Unique Aero Slot design reduces rotating weight and promotes even heat dissipation

### Evolution 2 Piston Kit

- Low friction Ball Bearings, Steel and Ceramic available
- Weight: 19.65 lbs
- Minimum Rotor thickness: 0.260"
- Minimum Pad Thickness: 0.200"
- Low friction seal and stainless steel seal rings

#### Before you begin installation:

- Strange Engineering brake kits are designed for DRAG RACING ONLY!
- Read these instructions thoroughly and save for future reference.

-If after reading these installation instructions, you have any questions or comments, please do not hesitate to call us.

### KIT CONTENTS

ITEM#	PART#	QTY	DESCRIPTION	ITEM#	PART#	QTY	DESCRIPTION
1	B1500H	2	Evolution hub cap	14	B1380B	10	5/8 ID x .025 Shim
2	S3520F	2	-222 Buna O-ring	15	B1380C	10	1/2 ID x .025 Shim
3	B1500F	2	0.751" ID outboard bearing sleeve	16a	B4710BR	1	Caliper Mount -RH
				16b	B4710BL	1	Caliper Mount -LH
5	B1524A	2	Evolution Front Hub	17	B1301E	4	3/8-24 Plug nut
6	A1028A	10	1/2-20 X 2.5" Taper head SHCS	18	B1301H	16	3/8 ID x .025 Shim
7	A1028B	10	1/2" Stripper washer	19	B2570	2	2-Piston Evolution caliper
8	B2788AS	2	11" Evolution rotor	20	B2510	4	DTC-30 semi metallic brake pad
9	B2794D	2	Spirolok				
11	B1500I	2	Seal	21	P2316	2	-1/8 NPT x #3AN Brake Line Fitting
12	B1500E	2	1.251" ID inboard bearing sleeve	22	B1301J	4	Washer -3/8 ID 1/16 thick
13	B4110A	2	5/8-18 x 1.25" FHSCS	23	S3440D	4	3/8-24 X 1 HHCS

### Ball Bearing Kits

#### B1500SKIT Steel Ball Bearing kit content

#### B1500CKIT Ceramic Ball Bearing kit content

ITEM#	PART#	QTY	DESCRIPTION	ITEM#	PART#	QTY	DESCRIPTION
4a	B1500B	2	Outboard Steel Ball bearing	4b	B1500BC	2	Outboard Ceramic Ball bearing
10a	B1500A	2	Inboard Steel Ball bearing	10b	B1500AC	2	Inboard Ceramic Ball bearing

**Installation instructions**

**Figure # 1**



1. Raise and support front of vehicle on a level surface using suitable equipment.
2. Remove wheel, stock drum, hub, brake line, and backing plate from spindle.
3. Clean and inspect spindle for damage (spun wheel bearings, stripped threads, etc.) and repair or replace as needed. Inspect upper and lower ball joints for excessive play and replace as needed.
4. Install 1/2" Dia. wheel studs (6) in front hub (5) using 1/2" I.D. wheel stud washer (7) and a small amount of BLUE Loc-tite®. Torque all studs to 65 ft-lbs.  
**Note:** Consult your wheel and/or lug nut manufacturer for proper lug nut torque.
5. Install the caliper mounting bracket (16) with the heads of the press nuts (17) facing towards the outboard side of the vehicle.
6. Use one 5/8" flat head bolt (13), finger tight, to hold the caliper bracket in place.
7. Use the 1/2" shims (15) on the bottom bolt to equalize the mounting surfaces.
8. Slide the hub assembly onto the spindle and install the stock spindle washer and nut.  
**Note:** Evolution rotors mount with the arrow pointing in the direction of normal rotation ( See Figure #1)
9. Measure the distance between the inboard face of the rotor and the outboard face of the caliper mounting bracket. Add or remove 1/2" and 5/8" shims as needed to obtain a distance of approximately 1/4" (+/- 1/32"). **Note:** Because all spindles vary slightly, you may have shims left over. Also, you may not need the same amount of shims on both sides of the vehicle.
10. Tighten the spindle nut until the hub has no end play and spins freely.
11. Install the cotter pin, aluminum hub cap (1), and remove the wheel and tire.
12. Torque the 5/8" flat head bolt (13) to 50 ft/lbs. Torque the lower bolt to 40 ft/lbs.  
 - Please read **B1835** instructions for complete caliper instructions.
13. Attach caliper (19) using 3/8"-24 caliper bolts (23) with red loctite and 3/8" I.D. flat washers (13). Use 3/8" I.D. caliper shims (18) to center the caliper over the rotor, making sure pads contact the rotor evenly. Torque the caliper mounting bolts (23) to 35 ft-lbs.
14. Connect the hydraulic lines to the calipers. Calipers are tapped to 1/8"-27 NPT and supplied with -3AN fittings. Use proper adapters to connect them to existing lines or use new -3AN braided steel line (teflon lined). Bleed the calipers with DOT 4 or DOT 5.1 brake fluid ONLY .

**Notes:** A proper break in procedure is required to avoid brake fade and uneven rotor deposits from the pads. It consists of 8-10 brake applications increasing in harshness while allowing the brakes to cool slightly in between; do not keep the brakes applied between stops. After the last stop the brakes should be allowed to cool completely. Operate the vehicle in a cautious manner until you determine that the brakes are functioning properly. Routinely check and re-torque all bolts.

**FIGURE # 2: Exploded B4710WCE Assembly View**

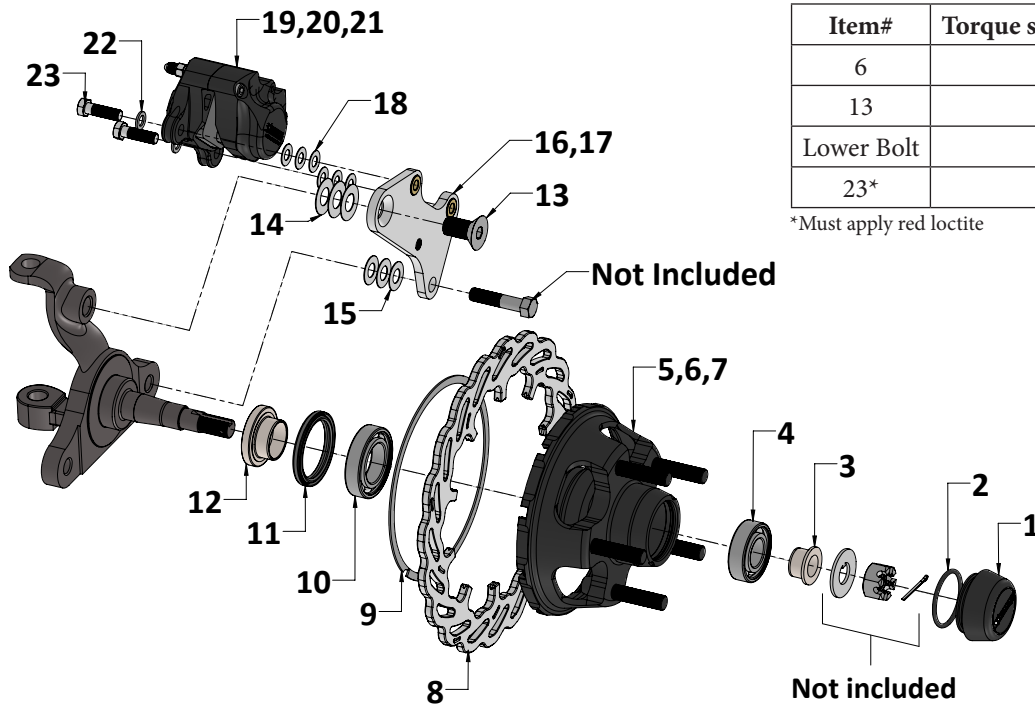

**WARNING - RACING IS HAZARDOUS · STRANGE BRAKES ARE FOR LEGAL DRAG RACING ONLY**

Disclaimer of Warranty - Purchasers using Strange Engineering racing components and equipment any and all inventory services, purchasers acknowledge that due to differing conditions and circumstances under which all equipment and parts are installed and used, purchasers are not relying on Strange Engineering Co. skill or judgment to select or furnish the proper part or equipment. Purchasers expressly affirm they are relying upon their own skill or judgment to select and purchase suitable goods.

Strange Engineering Co. makes no warranties whatsoever, expressed or implied, oral or written, to purchasers. There is no warranty of merchantability made to purchasers. Strange Engineering Co., further excludes any implied warranty of fitness with respect to racing and equipment, any and all inventory and service.