

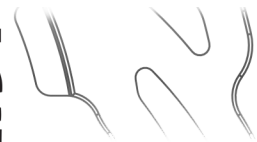

Strange



EVOLUTION SINGLE-PISTON FRONT BRAKE KIT INSTRUCTIONS

KIT #
B4500WCE - Lightweight single piston front brake kit

APPLICATIONS
Santhuff, Afco, Menscer struts
- Call for Afco & Menscer struts with ball bearings

Evolution Rotors

- Dynamic Drive Mount (DDM) system secures the rotor and allows for rotor thermal expansion
- DDM system design is secured by an internal Spirolox, eliminating heavy bolts and hardware
- Unique Aero Slot design reduces rotating weight and promotes even heat dissipation

Before you begin installation:

-Strange Engineering brake kits are designed for DRAG RACING ONLY!

-Read these instructions thoroughly and save for future reference.

-If after reading these installation instructions, you have any questions or comments, please do not hesitate to call us.

B1817 KIT CONTENTS

ITEM#	PART#	QTY	DESCRIPTION
1	B1260E	2	1/4" Stripper Washer
2	B1260I	4	3/8"-16x3" bolt
3	B1262J	2	Bridge Bolt Tube
4	B1250K	2	1/4"-20x3" bridge bolt
5	S3402N	12	3/8" AN Washer
6	B5000T	2	.125" Square O-Ring
7	L4000O	2	1/8" NPT Socket Plug
8	P2316	2	1/8" NPT x #3 AN fitting
9	P2365F	2	1/8" NPT Bleeder Assembly
10	B1270A	2	Single Piston Caliper (outboard half)
11	B1270B	2	Single Piston Caliper (inboard half)
12	B5000S1	2	Caliper Piston
13	B1250H	4	Garlock 08-DU06 Bearing (installed in B1260DC)
14	B1260K	4	Garlock 05-DU06 Bearing (installed in B1260CC)
15	B3311C	4	Slide Pin
16	F1282	8	3/8"-24 Jet Nut
17	B1270C	2	"Hotdog" Bracket (inboard)
18	B1270D	2	"Hotdog" Bracket (outboard)
19	B2510	4	Soft-Metallic brake pads

B4500WCE KIT CONTENTS

ITEM#	PART#	QTY	DESCRIPTION
20a	B4502AR	1	RH - Caliper mount
20b	B4502AL	1	LH - Caliper mount
21	B4502B	2	Wheel spacer (Afco & Menscer only)
22	F1237D	4	3/8"-24 x 3/4" FHCS
23	B2788AS	2	Evolution S Rotor
24	B1250SD	2	Front rotor adapter
25	B2794D	2	Spirolock
26	B1270	2	Single-Piston Caliper
27	F1282	4	3/8"-24 Jet Nut
28	S3402N	4	3/8" AN Washer
29	R5211E	2	3/8"-24 x 7/8" HHCS
30	B1328B	2	Wheel Seal (Afco & Menscer only)

Installation instructions

1. Mount the rotor (23,24,25) on the wheel using 3/8” studs and nuts supplied with the your wheel. Torque to approximately 35 ft-lbs.
2. Disassemble caliper by removing 3/8” caliper bolts (2) and the caliper bridge bolt (4). The slide pins (15) should remain attached to the bracket.
3. Attach the caliper mounting bracket (20) to the strut body using 3/8”-24 HHCS (29), 3/8”-24 FHSCS bolt (22), 3/8” washer (28) and jet nut (27). Torque to 35 ft-lbs.
4. Install the provided wheel spacer (21) with the note on the spacer facing outboard
Note: View in Figure #1 for reference, applies to Afco and Menscer only.
5. Follow the Manufacturer instructions to assemble the wheel onto the strut body.
6. After the wheel is assembled, firmly tighten the castle nut and then back it off. This will ensure the wheel spacer (21) is properly seated on the strut. Tighten back to the recommended torque in the manufacturer instructions.
7. The caliper now must be assembled onto the bracket. Using Figure 2 to assist you in making sure it is properly assembled. Install the inboard half of the caliper (11) along with the “hotdog” bracket (17) onto the slide pin (15). Insert one brake pad (19), and also insert the caliper bridge bolt (4), washer (1), and tube (3).
8. Slide the outboard “hotdog bracket” (18) over the slide pins.
9. Feed the outboard half of the caliper (10) either through the outside of the wheel or over the rotor.
10. Line up the outboard caliper half and brake pad and loosely secure with the caliper bridge bolt.
11. Re-install the 3/8” caliper bolts (2), making sure to use a washer (5) under the heads of the bolts. Torque 3/8” bolts to 30 ft-lbs and bridge bolt to 8-10 ft-lbs.
12. Connect the hydraulic lines to the calipers. Calipers are tapped to 1/8”-27 NPT and supplied with -3AN fittings. Use proper adapters to connect them to existing lines or use new -3AN braided steel line (Teflon lines). Bleed calipers with DOT 4 or DOT 5.1 brake fluid ONLY.

A proper break in procedure is required to avoid brake fade and uneven rotor deposits from the pads. It consists of 8-10 brake applications increasing in harshness while allowing the brakes to cool slightly in between; do not keep the brakes applied between stops. After the last stop the brakes should be allowed to cool completely.

Note: After the initial installation of this kit, ensure that there is adequate clearance between all braking and chassis components by turning the wheels all the way left to right and moving them all the way up and down throughout the length of the wheel (suspension) travel. Additionally, make sure that the brake lines are not interfering with the wheel travel, or subject to binding or kinking. Operate the vehicle in a cautious manner until you determine that the brakes are functioning properly. Routinely check and re-torque all bolts.

FIGURE # 1: Exploded B4500WCE Assembly View

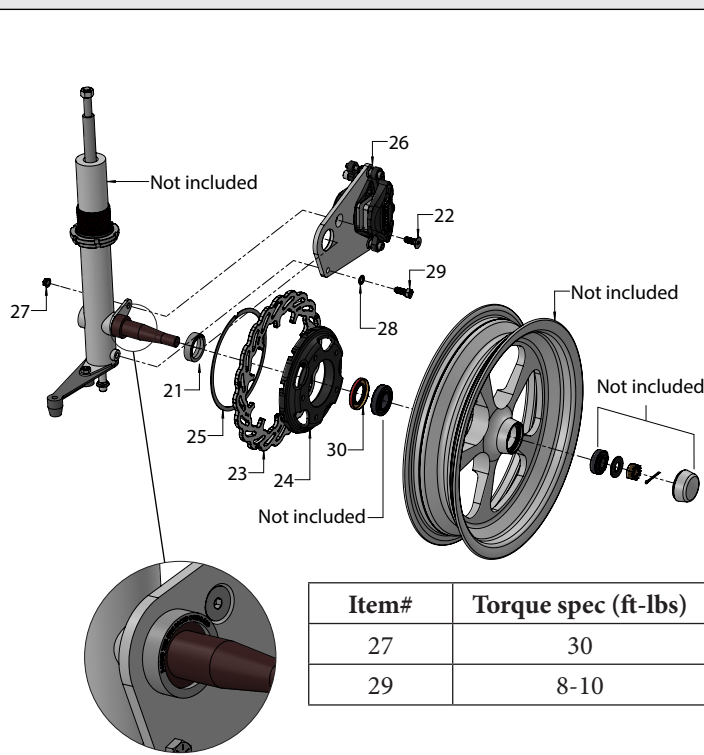

FIGURE # 2: Strange Evolution 1 Caliper Components

