

## Installation instructions for Strange Sportsman 11" Rear Carbon Brake Kit for Early Big Ford Housing ends with 4.75" (C17084WC) or 5" (C17085WC) Bolt Circle

### Important Notes:

- Strange Engineering brake kits are designed for **DRAG RACING ONLY!**
- Carbon brake pads (L4050HS) minimal thickness is 0.200".
- 11" Carbon rotors (C1790) minimal thickness is 0.300".

### Before you begin installation:

Read these instructions thoroughly and save for future reference.

If after reading these installation instructions, you have any questions or comments, please do not hesitate to call us.

### KIT CONTENTS

Item#	Part#	Qty.	Description
1	H1135B	8	Big Ford Housing End Stud
2	H1135C	8	1/2"-20 Flexlok Nut
3	A1026B	8	1/2" Flat Washer
4	C1708A	2	Carbon Caliper Mounting Bracket
5	B1301E	4	3/8"-24 Press Nut
6*	C1700B*	1*	RH carbon rotor adapter for use with 4 3/4" b.c.
6*	C1700F*	1*	RH carbon rotor adapter for use with 5" b.c.
7*	C1700C*	1*	LH carbon rotor adapter for use with 4 3/4" b.c.
7*	C1700G*	1*	LH carbon rotor adapter for use with 5" b.c.
8	C1700D	20	1/4"-20 x 1 1/2" FHSCS
9	C1700H	2	11" Carbon rotor retainer ring
10	C1790	2	11" Carbon rotor
11	B1301H	16	3/8" ID x 1/4" Caliper shim
12	B1301J	4	3/8" ID x 1/16" Caliper washer
13	B5000Z	4	3/8"-24 x 1.187" Caliper mounting bolt
14	B5002MD	1	Right Hand 4-Piston Caliper (carbon)
15	B5004MD	1	Left hand 4-piston Caliper (carbon)
16	L4050HS	4	Soft carbon brake pad
17	L4050S	4	.024" Titanium heat shield (installed in B5002MD & B5004MD)
18	L4050T	4	.060" S.S. heat shield
19	P2316	2	1/8" NPT x #3 AN Fitting

\*Kit contents will depend on application based on bolt circle diameter. (does not affect assembly)

**Figure #1: Driver Side**

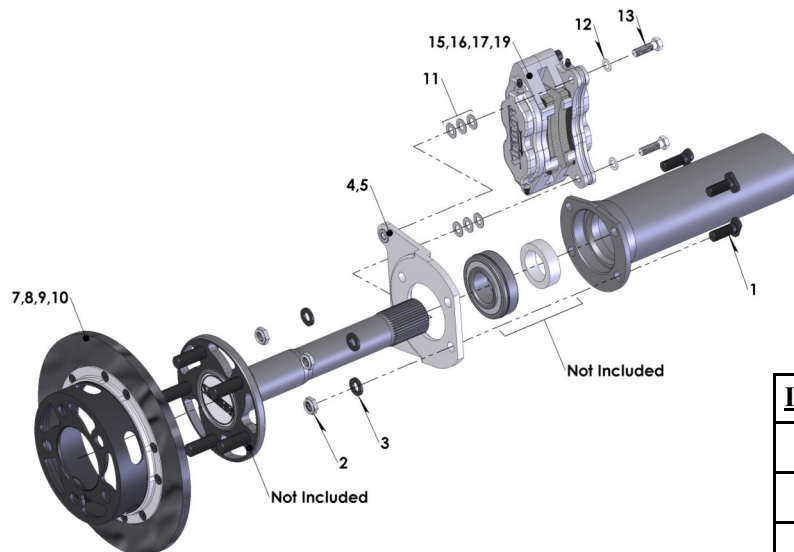

Item #	Torque Spec (ft-lbs)
2	40
8	10-15
13	35

## Installation instructions for C17084WC & C17085WC

1. Raise and support rear of vehicle on a level surface using suitable equipment.
2. Remove wheel, axle, and current brakes.
3. Remove bearing, wedding ring, and existing brake bracket from axle.
4. Check the axle for any signs of twisting or run out and repair or replace as needed. The maximum allowable run out checked between centers at the face of the flange, bearing surface, and near the splines is 0.005" total indicated run out (T.I.R.).
5. Inspect the rotor assembly for fit on the axle flange. The rotor adapter (6,7) should slide freely over the axle flange and seat flush against the face of the axle flange. The rotor adapter (6,7) must center on the axle flange or axle studs. If the axle flange is too large, it must be machined to 6.240" diameter.
6. Visually inspect the housing end for straightness and repair as needed.
7. Replace housing end studs with new Big Ford stud (1).
8. Slide the caliper mounting bracket (4) on the axle with the press nuts (5) facing **OUTBOARD**.
9. Install a new bearing (not included) on the axle, pressing only on the inner race, making sure the seal faces the axle flange. Before installing apply a small amount of oil to the I.D. of the bearing to aid in installation. Make certain that the bearing fully seats against the step on the axle.
10. Press the wedding ring (not included) onto the axle until it seats flush against the bearing.
11. Slide the axle into the housing until the bearing bottoms out in the housing end.
12. Engage the carbon caliper bracket (4) over the new Big Ford Studs (1) and install using the 1/2-20 Flexlok nuts (2) and 1/2" washer (3).  
Torque to 40 ft-lbs.  
*Note:* The caliper bracket (4) can be mounted facing either the front, or rear of the vehicle, or straight up, depending on application and/or desired orientation.
13. Slide the rotor assembly over the wheel studs and axle flange, ensuring that the rotor sits flat on the face of the axle flange. Rotors come preassembled from Strange Engineering. However, if you ever need to disassemble the rotor, reassemble it by placing the rotor (10) between the retaining ring (9), and the adapter (6,7). Secure using 1/4-20 x 1/2" flat head socket bolts (8) and torque to 10-15 ft-lbs. Re-torque before every event to 10-15 ft-lbs.  
*Note:* During re-assembly of rotor ensure that the large counterbore on the 11" carbon rotor (10) faces **OUTBOARD**; otherwise the retainer ring (9) will not fully seat on the rotor (10) and **FAILURE** will occur. (Refer to figure 2)  
**-Please read B5055 instructions for complete carbon brake caliper instructions.**
14. Attach caliper (14,15) with the arrow facing in the direction of normal rotor rotation using 3/8"-24 caliper bolts (13) and 1/16" thick flat washers (12). Use 0.025" thick caliper shims (11) to center the caliper over the rotor, making sure pads contact the rotor evenly. The caliper bolt (13) should be fully engaged into the press nut (5). If the bolt is over engaged, use any remaining shims under the head of the bolt to prevent it from running into the rotor. Torque the caliper mounting bolts (13) to 35 ft-lbs.  
*Note:* Calipers are directional and must mount with the arrow pointing in the direction of normal rotation. Refer to B5055 instructions for detailed caliper information.
15. Connect the brake lines to the calipers. Calipers are tapped to 1/8"-27 NPT and supplied with -3AN fittings. Use proper adapters to connect them to existing lines or use new -3AN braided steel line (teflon lined). Bleed the calipers with DOT 4 or DOT 5.1 brake fluid **ONLY**.

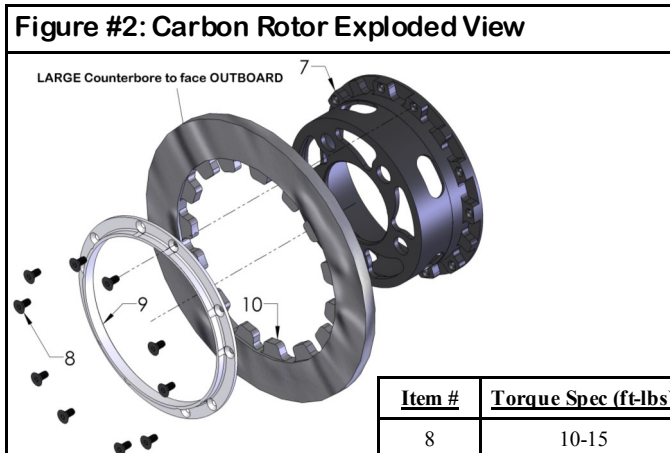

**Note:** After the initial installation of this kit, ensure that there is adequate clearance between all braking and chassis components by moving the suspension all the way up and down throughout its travel. Additionally, make sure that the brake lines are not interfering with the wheel travel, or subject to binding or kinking. Operate the vehicle in a cautious manner until you determine that the brakes are functioning properly. Check and re-torque all bolts before every event.

**Note:** Rear Carbon Brakes perform best with caliper pressure from 1,100-1,200 psi

**Note:** Pads should be replaced when thickness equals .200" or less (thicker heat shields to be used as pads wear). Replace rotors when thickness equals .300" or less. Rotors wear concave and pads wear convex; therefore, measure rotor thickness in the middle of the rotor and pad thickness in the area where there are no pistons.

**Note:** Keep Carbon away from all chemicals. If contamination occurs the carbon component must be baked for 8 hours @ 500° F-(**Bake Carbon ONLY! REMOVE ALUMINUM HAT & HARDWARE BEFORE BAKING**)- If badly contaminated an odor will occur.

**Note:** The **HOTTER** the rotors become, the **MORE EFFECTIVE** braking becomes. Carbon brakes will stop your vehicle far better at the "top end" and will not "hold" as well at the starting line, compared to steel brakes. We recommend that when you first drive or "tow" your vehicle to the starting line, you apply the brakes several times to get the "feel" of carbon at low speeds. After you become comfortable with the vehicle at "pit area" speeds, you may want to "drag" the brakes to create rotor and pad heat to better hold the vehicle at the starting line. We recommend a few 1/2 or 3/4 passes, so as to become aware of how your carbon brakes perform at higher M.P.H. Remember carbon works better at higher temperature. The longer the brakes are applied the more aggressive braking will become.

### WARNING – RACING IS HAZARDOUS · STRANGE BRAKES ARE FOR LEGAL DRAG RACING ONLY

**Disclaimer of Warranty –** Purchasers using Strange Engineering racing components and equipment any and all inventory services, purchasers acknowledge that due to differing conditions and circumstances under which all equipment and parts are installed and used, purchasers are not relying on Strange Engineering Co. skill or judgment to select or furnish the proper part or equipment. Purchasers expressly affirm they are relying upon their own skill or judgment to select and purchase suitable goods. Strange Engineering Co. makes no warranties whatsoever, expressed or implied, oral or written, to purchasers. There is no warranty of merchantability made to purchasers. Strange Engineering Co., further excludes any implied warranty of fitness with respect to racing and equipment, any and all inventory and service.