

Strange

Kit Summary:

Kit #	A1092
Description	C-clip eliminator kits with roller ball bearing
Applications	1986-93 8.8" Ford housing end with stock axle 1.399" H bearing journal diameter (except for disc or truck brakes)
Page	1 of 2 total pages
Date Modified	Feb 6, 2016

Kit Contents

ITEM#	PART#	QTY	DESCRIPTION
1	A1092B	2	Safety Hub Outer Half (<i>threaded half</i>)
2	A1032C	2	Axle Bearing
3	--	2	Wedding Ring (<i>included with bearing</i>)
4	A1092C	8	$\frac{3}{8}$ "-24 x 1" & $\frac{3}{8}$ "-16 x $\frac{3}{4}$ " total length 2- $\frac{1}{2}$
5	A1092A	2	Safety Hub Inner Half
6	A1030C	2	Axle Seal (<i>National #41013S</i>)
7	A1092E	4	Hub Gasket
8	S3402N	8	$\frac{3}{8}$ " Washer
9	F1282	8	$\frac{3}{8}$ "-24 Nut

Housing Preparation (*refer to figure 1*)

1. Remove wheel and tire, drum and axle from the housing (*axle c-clip must be removed first*).
2. Disassemble the rear drum kit and remove the studs and backing plate from the housing end flanges.
3. Remove the stock bearing and seal from the housing snouts.
4. Refer to figure 1 and shorten the housing snout leaving the register for the backing plate only.
5. Remove any rust, dirt, burrs or grease from the modified housing and both seating surfaces of the backing plate.

Axle Preparation (*refer to figure 2 and 3*)

6. Press the the outer half (1) with the pre-installed studs (4) and bearing (2) over each axle shaft with the small bore of the hub facing the axle flange.

Note: Press only on the inner race of the axle bearing.

Ensure the axle bearing is installed with the o-ring facing the splined end of the axle.

Press the bearing on until 2.00" is achieved from the axle flange to inboard side of bearing.

7. Press the wedding (3) rings on. The wedding ring is a press fit and should seat firmly against the bearing. There should be no movement of the bearing inner race.
8. Slide the inner half (5) with the pre-installed seal (6) onto the axle mating it respectively with the outer half.

Axle Installation (*refer to figure 3*)

9. Apply a thin coating of RTV sealer to both sides of the hub gaskets (7).
10. Re-install the brake backing plate with gaskets.
11. Coat the spline portion of the axle with white lead compound or grease. This will help determine axle spline engagement.
12. Carefully position and re-install the axle with the safety hub assembly into the housing, engaging the studs thru the backing plate, gaskets and housing end.

Note: Due to a variety of differentials and gear ratios ensure the axle shafts do not contact the differential cross pin.

The axle must be cut if it makes any contact. Contact can be checked by coating the ends of the axle with white lead compound or grease.

15. Remove the axle from the housing and ensure spline engagement is at minimum 1".
16. Re-assemble the axle into the housing and torque the housing end jet nuts (9) to 35 ft-lbs.

FIGURE # 1: Housing Modification

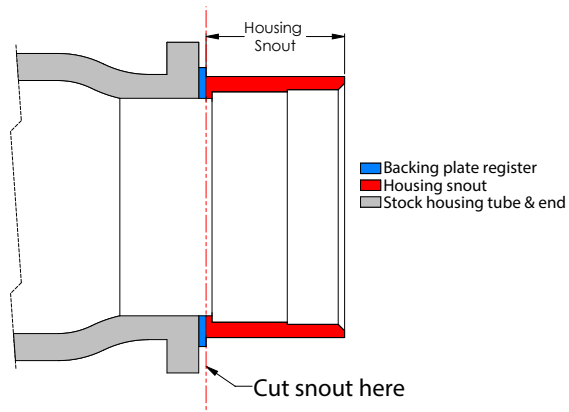

FIGURE # 2: Axle bearing install

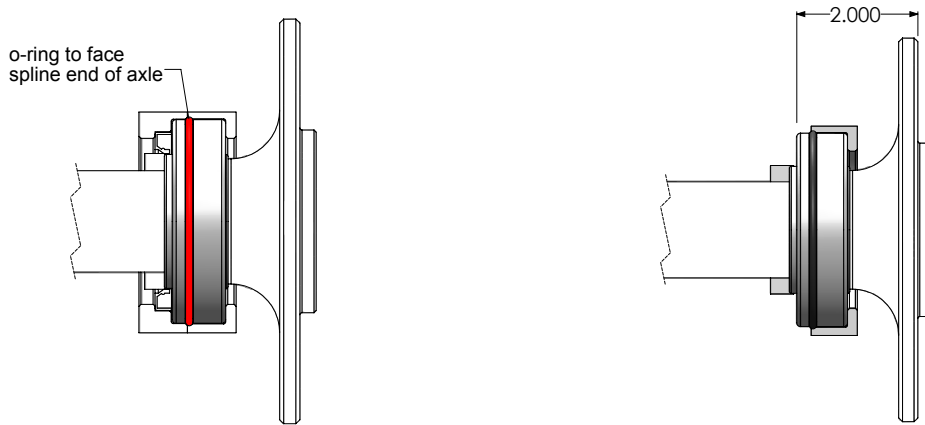

FIGURE # 3: Exploded view

