

Rebuild

Kit # B5109

Applications: B1851

Instructions

Caliper Rebuild Kit

Strange Directional Four Piston Caliper

IMPORTANT NOTES:

- B5109 Strange Directional Four Piston Brake Caliper o-ring rebuild kit is sold per caliper.
- Air supply and blow gun are required for removing the caliper pistons.
- Hydraulic brake assembly lubricant is recommended for maximum protection and ease of installation.
- Ensure brake pads and rotors are not below minimum thicknesses specified below.

BEFORE YOU BEGIN INSTALLATION:

Read these instructions thoroughly and save for future reference. If after reading these installation instructions, you have any questions or comments, please do not hesitate to call us.

B5109 Rebuild Kit O-Rings			
Item#	Part#	Qty.	Description
8	B5002D	2	1.62" x .100" wide O-ring
9	B5000U	2	1.75" x .100" wide O-ring
10	B5002F	1	Crossover port O-ring
B5002 (passenger) & B5004 (driver) Four Piston Directional Caliper Components <i>(parts listed below are not included)</i>			
1	—	1	Bridge Bolt
2	—	4	1/8" NPT Bleeder Assembly
3	—	2	1.75 Dia. Caliper Piston
4	—	2	1.625 Dia. Caliper Piston
5	L4050S	2	0.024 Thick Brake Pad Heat Shield
6	L4050T	2	0.060 Thick Brake Pad Heat Shield
7	—	1	Bridge Bolt Tube
11	—	4	5/16" ID Washer
12	—	4	5/16-18 x 2.00" Caliper Bolt
13	—	1	Caliper Bridge Bolt Nut
14	P2316	1	1/8 NPT x #3AN Fitting

Brake Rotors Minimum Thicknesses		
Part#	Description	Min. Thickness
B2792/B2793	11.25" Dia. Steel Rotor	0.312"
C1790	11" Dia. Carbon Rotor	0.300"

All carbon, metallic & semi-metallic brake pads minimum thicknesses are 0.200"

Figure One: Strange Directional Caliper Exploded View

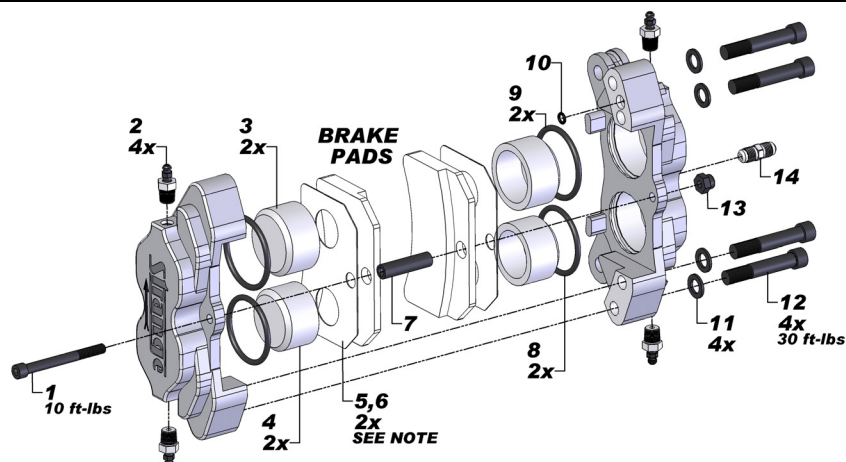

Note: Heat shields (5,6) used with only carbon brake pads.

Rebuild Instructions

Kit # B5109
Caliper Rebuild Kit

Applications: B1851
Strange Directional Four Piston Caliper

1. Use a 3/16" hex bit socket to remove the bridge bolt (1).
2. Slide the brake pads and bridge bolt tube (7) out of the caliper assembly.
3. Use a 5/16" hex bit socket to unscrew the four caliper bolts (12). Separate the two caliper halves.

Figure 1: Four Caliper Bolts Removal

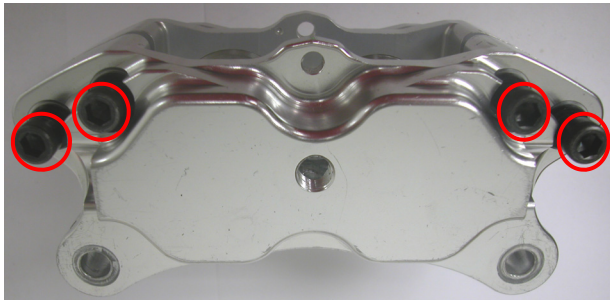

8. Apply hydraulic brake assembly lubricant to piston seals (8,9) and caliper pistons (3,4) to ease with reassembly and for protection.
Notes: Use only brake assembly lubricant designed for caliper pistons and rubber components.
9. Install new piston seals (8,9). Ensure the seals seat properly in the caliper half grooves.

Figure 3: Square Piston Seals Installation

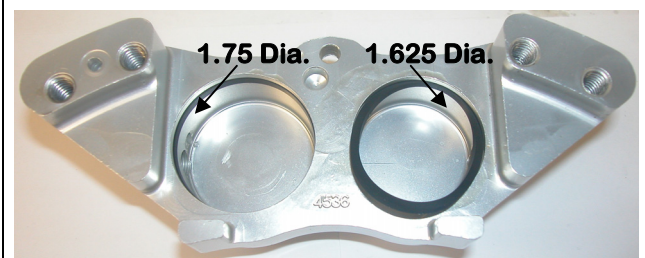

4. Place a piece of wood or metal on the inside face of a caliper half and use a c-clamp to hold the piece in place. A vice can also be used. Position the piece of wood or metal so the crossover port is exposed. Supply air to the crossover port until the pistons slides out as far as possible. If working on the inboard caliper half the fitting on the back of the caliper must be blocked to prevent air from escaping. Remove the caliper pistons entirely from the caliper half.

Notes: Rags shown in picture are used to prevent cosmetic damage. Rags should also cover the entire assembly when air is supplied so it catches any remaining brake fluid. The bleeder assemblies must be closed during this procedure.

Figure 2: Caliper Piston Removal

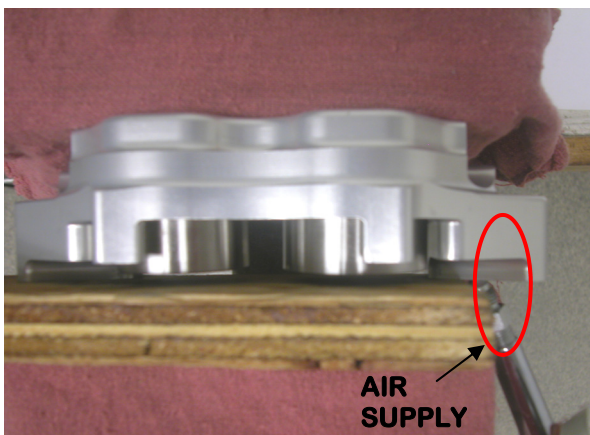

10. Push the caliper pistons evenly into the caliper halves.
11. Install the new crossover port o-rings (inboard half).

Figure 4: Crossover Port O-Rings



12. Align the two caliper halves together and begin to screw the four caliper bolts. Torque caliper bolts to 30 ft-lbs.

Figure 5: Caliper Halves



5. Remove the old piston seals (8,9).
6. Use a brake parts cleaner to clean the caliper pistons and bores.
7. Inspect the caliper pistons and bores for any major scuffs, scratches or unusual damage. Replace as needed.

13. Reinstall the brake pads with the bridge bolt tube (7) and align with bridge bolt (1). Torque bridge bolt to 10 ft-lbs.
14. Refer to brake caliper kit instructions for reinstalling the brake caliper onto the vehicle.