

# Axle Order Form

847-663-1701

FAX 847-663-1702



**BILLING ADDRESS**

Name: \_\_\_\_\_

Phone: \_\_\_\_\_

Address: \_\_\_\_\_

City \_\_\_\_\_ State \_\_\_\_\_ Zip \_\_\_\_\_

**SHIPPING ADDRESS**  (same as billing)

Name: \_\_\_\_\_

Phone: \_\_\_\_\_

Address: \_\_\_\_\_

City \_\_\_\_\_ State \_\_\_\_\_ Zip \_\_\_\_\_

**ORDER DETAILS**

Package # \_\_\_\_\_

Additional Parts & Options: \_\_\_\_\_

**AXLES** The information below is required for all orders

Application (check all that apply)  street  strip  circle  other \_\_\_\_\_

Axle Type  alloy  alloy (c-clip style)  hy-tuf

Carrier Brand & Type (posi, spool...) \_\_\_\_\_

Brake Description (drum, disc, manufacturer...) \_\_\_\_\_

Spline Count \_\_\_\_\_ Bolt Circle \_\_\_\_\_ A \_\_\_\_\_ D \_\_\_\_\_

**WHEEL STUD INFORMATION**

Bolt Head Style Wheel Studs  1/2"-20 x 2"  
 1/2"-20 x 3"  
 5/8"-18 x 3"

Press-in Wheel Studs \_\_\_\_\_

Thread & Length (applicable to alloy axles only!) \_\_\_\_\_

Hole Diameter for Custom Studs \_\_\_\_\_

**MEASURING PRE-EXISTING AXLES FOR UPGRADE**

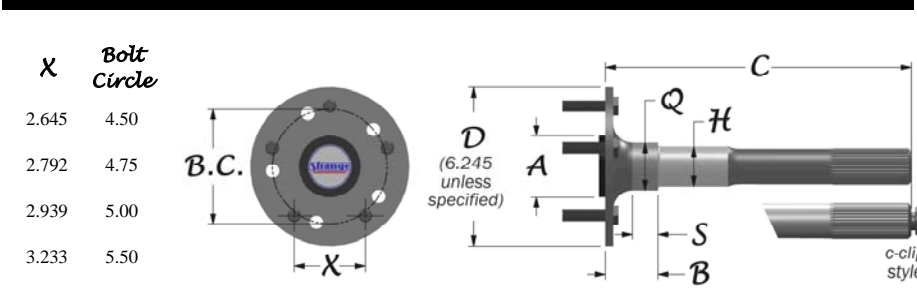

**DIMENSIONS**

B \_\_\_\_\_

H \_\_\_\_\_

Q \_\_\_\_\_

S \_\_\_\_\_

Driver Side C \_\_\_\_\_

Passenger Side C \_\_\_\_\_

**MEASURING REAR END FOR UPGRADING AXLES**

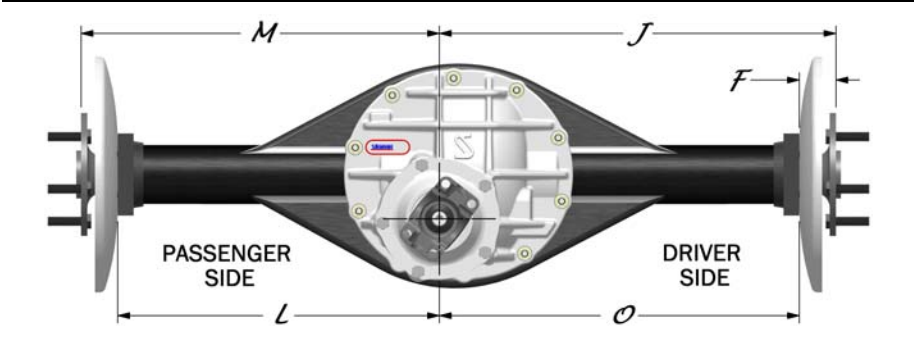

**DIMENSIONS**

F \_\_\_\_\_

J \_\_\_\_\_

M \_\_\_\_\_

Wheel to Wheel (J + M) \_\_\_\_\_

O \_\_\_\_\_

L \_\_\_\_\_

Housing End to Housing End (O + L) \_\_\_\_\_

**INDICATE TYPE OF HOUSING END** Check the corresponding box next to the housing end type.

|  |  |   |  |  |  |  |
|--|--|---|--|--|--|--|
| <input type="checkbox"/> Strange Ford 8.8" H1138 | <input type="checkbox"/> Factory Ford 8.8" H1138 | <input type="checkbox"/> Big Ford H1135   | <input type="checkbox"/> Late Big Ford H1137 H1148 | <input type="checkbox"/> Mustang H1134 | <input type="checkbox"/> Factory 05-up Mustang | <input type="checkbox"/> Olds H1132 H1142  |
| <input type="checkbox"/> Strange Small GM H1143  | <input type="checkbox"/> Factory Small GM        | <input type="checkbox"/> Factory Large GM | <input type="checkbox"/> Mopar H1133               | <input type="checkbox"/> Mopar H1147   | <input type="checkbox"/> Symmetrical H1131     | <input type="checkbox"/> Symmetrical H1136 |

# Axle Order Form

## Dimension Definitions & Common Sizes



- A** Brake Register  
Centers the factory OEM brake drum or rotor and where applicable the wheels. Rotors applied in drag racing are typically centered by the wheel studs and have an oversized center allowing compatibility with various brake register sizes.  
Chrysler/Dana/Mopar common *A* dimensions: 2.300 or 2.820  
Ford common *A* dimensions: 2.430, 2.525, 2.750, 2.780, 2.796, 2.875 or 3.060  
General Motors common *A* dimensions: 2.780, 2.812 or 3.060
- B** Bearing Shoulder  
This is the bearing stop machined on the axle. This feature is not applicable to c-clip style axles. This is not identical to the *F* axle offset dimension since most axle bearings protrude from the housing end. The type of bearing, sealed ball or tapered, will result in a different axle offset using the same *B* dimension. If an original type of bearing is not used then the *B* dimension will need to be changed in order to maintain the original wheel offset.  
Chrysler/Dana/Mopar common *B* dimensions: 2.200, 2.3125 or 2.5625  
Ford common *B* dimensions: 1.875, 2.0625, 2.125, 2.250, 2.375, 2.4375
- C** Axle Overall Length  
This dimension is taken from the outside face of the axle flange to the end of the splines. Driver side and passenger side typically have different *C* dimensions. Measurement must be precise, best accomplished by using a straight edge and tape measure. Please let us know if you have given a *C* dimension with an existing carrier and intend to change the carrier. The change may alter the *C* dimension.
- D** Axle Flange Diameter  
Ø 6.245 is the Strange Engineering standard axle flange diameter unless otherwise specified. Customer must request a different size if clearance with the rotor or drum is an issue.
- F** Axle Offset (Brake Gap)  
Measured from outside face of axle flange to the outside face of the housing end.  
Ford common *F* dimensions: 2.145, 2.3326, 2.500, 2.625  
General Motors common *F* dimension: 2.8325
- F** Axle Offset (Brake Gap) with Chrysler or Mopar Rearends  
Measured from outside face of axle flange to the outside face of the housing end. On Chrysler/Dana/Mopar type housing ends, *F* is obtained with the backing plate and gasket installed or combined thickness accounted for. If aftermarket disc brakes are being used then it's best to remove the axle bearing and supply the *B* dimension to ensure proper fitment of axles.  
Chrysler/Dana/Mopar common *F* dimensions: 2.3125, 2.423 or 2.673
- H** Bearing Journal Diameter  
Diameter on which the axle bearing is pressed onto. Dimension is not required if purchasing bearings with axle order.  
Chrysler/Dana/Mopar common *H* dimension: 1.5635  
Ford common *H* dimensions: 1.379, 1.400, 1.532, 1.563, 1.626 or 1.773  
General Motors common *H* dimensions: 1.379, 1.400, 1.532, 1.563, 1.626 or 1.773
- J** Distance from outside face of driver side axle flange to center of pinion
- L** Distance from outside face of passenger side housing end to center of pinion
- M** Distance from outside face of passenger side axle flange to center of pinion
- O** Distance from outside face of driver side housing end to center of pinion
- Q** Seal Journal Diameter  
Diameter on which the seal rides. Only necessary if the axle requires an outer seal, but the axle bearings are not being purchased
- S** Seal Journal Width  
The width of the seal journal diameter. Only necessary if the axle requires an outer seal, but bearings are not being purchased.
- X** Distance Between Centers of Wheel Studs for Calculating Bolt Circle  
Measurement is taken from the center of one wheel stud to the center of the wheel stud closest to it. This dimension is used as a reference to calculate the bolt circle (B.C.)  
Only applies to 5 wheel stud pattern.  
This does NOT apply to a 4,6 or 8 wheel stud pattern.